



Learn the architecture - An introduction to AMBA AXI

Version 3.0

Non-Confidential

Issue 03

Copyright © 2020–2022 Arm Limited (or its affiliates). 102202_0300_03_en
All rights reserved.

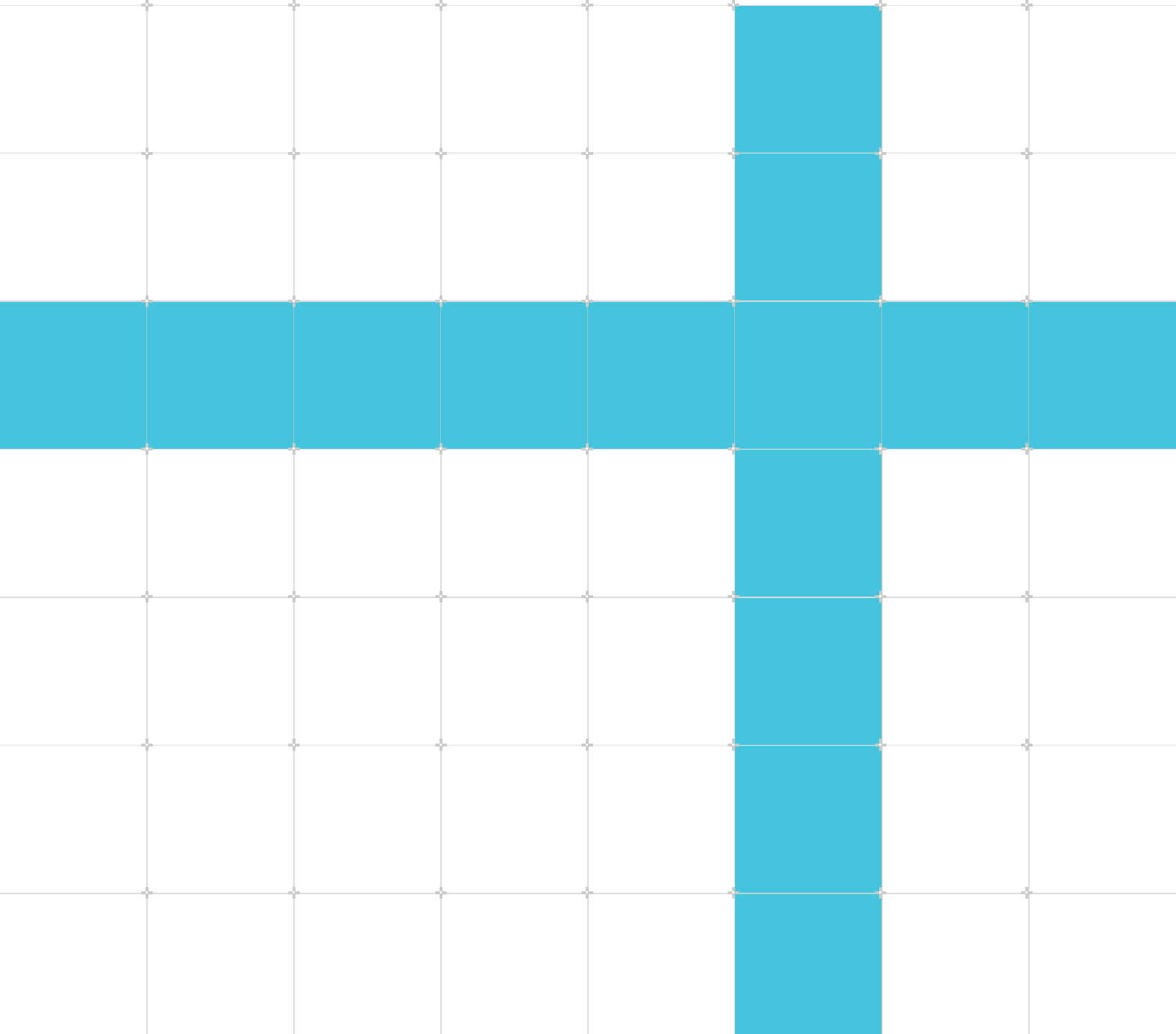

Learn the architecture - An introduction to AMBA AXI

Copyright © 2020–2022 Arm Limited (or its affiliates). All rights reserved.

Release information

Document history

Issue	Date	Confidentiality	Change
0100-01	25 August 2020	Non-Confidential	First release
0200-01	15 February 2021	Non-Confidential	Terminology updates
0300-02	12 March 2021	Non-Confidential	Clarifying transfers and transactions
0300-03	12 October 2022	Non-Confidential	Fixed minor technical issue

Proprietary Notice

This document is protected by copyright and other related rights and the practice or implementation of the information contained in this document may be protected by one or more patents or pending patent applications. No part of this document may be reproduced in any form by any means without the express prior written permission of Arm. No license, express or implied, by estoppel or otherwise to any intellectual property rights is granted by this document unless specifically stated.

Your access to the information in this document is conditional upon your acceptance that you will not use or permit others to use the information for the purposes of determining whether implementations infringe any third party patents.

THIS DOCUMENT IS PROVIDED “AS IS”. ARM PROVIDES NO REPRESENTATIONS AND NO WARRANTIES, EXPRESS, IMPLIED OR STATUTORY, INCLUDING, WITHOUT LIMITATION, THE IMPLIED WARRANTIES OF MERCHANTABILITY, SATISFACTORY QUALITY, NON-INFRINGEMENT OR FITNESS FOR A PARTICULAR PURPOSE WITH RESPECT TO THE DOCUMENT. For the avoidance of doubt, Arm makes no representation with respect to, and has undertaken no analysis to identify or understand the scope and content of, patents, copyrights, trade secrets, or other rights.

This document may include technical inaccuracies or typographical errors.

TO THE EXTENT NOT PROHIBITED BY LAW, IN NO EVENT WILL ARM BE LIABLE FOR ANY DAMAGES, INCLUDING WITHOUT LIMITATION ANY DIRECT, INDIRECT, SPECIAL, INCIDENTAL, PUNITIVE, OR CONSEQUENTIAL DAMAGES, HOWEVER CAUSED AND

REGARDLESS OF THE THEORY OF LIABILITY, ARISING OUT OF ANY USE OF THIS DOCUMENT, EVEN IF ARM HAS BEEN ADVISED OF THE POSSIBILITY OF SUCH DAMAGES.

This document consists solely of commercial items. You shall be responsible for ensuring that any use, duplication or disclosure of this document complies fully with any relevant export laws and regulations to assure that this document or any portion thereof is not exported, directly or indirectly, in violation of such export laws. Use of the word “partner” in reference to Arm’s customers is not intended to create or refer to any partnership relationship with any other company. Arm may make changes to this document at any time and without notice.

This document may be translated into other languages for convenience, and you agree that if there is any conflict between the English version of this document and any translation, the terms of the English version of the Agreement shall prevail.

The Arm corporate logo and words marked with ® or ™ are registered trademarks or trademarks of Arm Limited (or its affiliates) in the US and/or elsewhere. All rights reserved. Other brands and names mentioned in this document may be the trademarks of their respective owners. Please follow Arm’s trademark usage guidelines at <https://www.arm.com/company/policies/trademarks>.

Copyright © 2020–2022 Arm Limited (or its affiliates). All rights reserved.

Arm Limited. Company 02557590 registered in England.

110 Fulbourn Road, Cambridge, England CB1 9NJ.

(LES-PRE-20349|version 21.0)

Confidentiality Status

This document is Non-Confidential. The right to use, copy and disclose this document may be subject to license restrictions in accordance with the terms of the agreement entered into by Arm and the party that Arm delivered this document to.

Unrestricted Access is an Arm internal classification.

Product Status

The information in this document is Final, that is for a developed product.

Feedback

Arm welcomes feedback on this product and its documentation. To provide feedback on the product, create a ticket on <https://support.developer.arm.com>

To provide feedback on the document, fill the following survey: <https://developer.arm.com/documentation-feedback-survey>.

Inclusive language commitment

Arm values inclusive communities. Arm recognizes that we and our industry have used language that can be offensive. Arm strives to lead the industry and create change.

We believe that this document contains no offensive language. To report offensive language in this document, email terms@arm.com.

Contents

1. Overview.....	6
2. What is AMBA, and why use it?.....	7
3. AXI protocol overview.....	11
4. Channel transfers and transactions.....	17
5. Channel signals.....	30
6. Atomic accesses.....	41
7. Transfer behavior and transaction ordering.....	49
8. Check your knowledge.....	61
9. Related information.....	62
10. Next steps.....	63

1. Overview

This guide introduces the main features of Advanced Microcontroller Bus Architecture (AMBA) AXI. The guide explains the key concepts and details that help you implement the AXI protocol.

In this guide, we describe:

- What AMBA is.
- Why AMBA is so popular in modern SoC design.
- The concepts of transfers and transactions, which underpin how AMBA operates.
- The different channel signals and the functionality that they provide.
- Exclusive access transfers, which allow multiple managers to access the same subordinate at the same time.
- The rules and conditions that the AMBA protocol dictates.
- The key attributes and support for common elements like mixed endian structures.

This document focuses on the key concepts of AXI, as defined in AXI4, and highlighting differences to AXI3 where applicable. AXI5 extended AXI4 and introduced a number of performance and Arm architecture features. The key concepts described here still apply, but the additional functionality of AXI5 is not covered here.

At the end of this guide, you can [Check your knowledge](#).



Diversity and inclusion are important values to Arm. Because of this, we are re-evaluating the terminology we use in our documentation. Older Arm documentation, including the [AMBA AXI and ACE protocol specification](#), uses the terms master and slave. This guide uses replacement terminology, as follows:

-
- The new term manager is synonymous with master in older documentation.
 - The new term subordinate is synonymous with slave in older documentation.

2. What is AMBA, and why use it?

The Advanced Microcontroller Bus Architecture, or AMBA, is an open-standard, on-chip interconnect specification for the connection and management of functional blocks in system-on-a-chip (SoC) designs.

Essentially, AMBA protocols define how functional blocks communicate with each other.

The following diagram shows an example of an SoC design. This SoC has several functional blocks that use AMBA protocols, like AXI, to communicate with each other:

Figure 2-1: System diagram

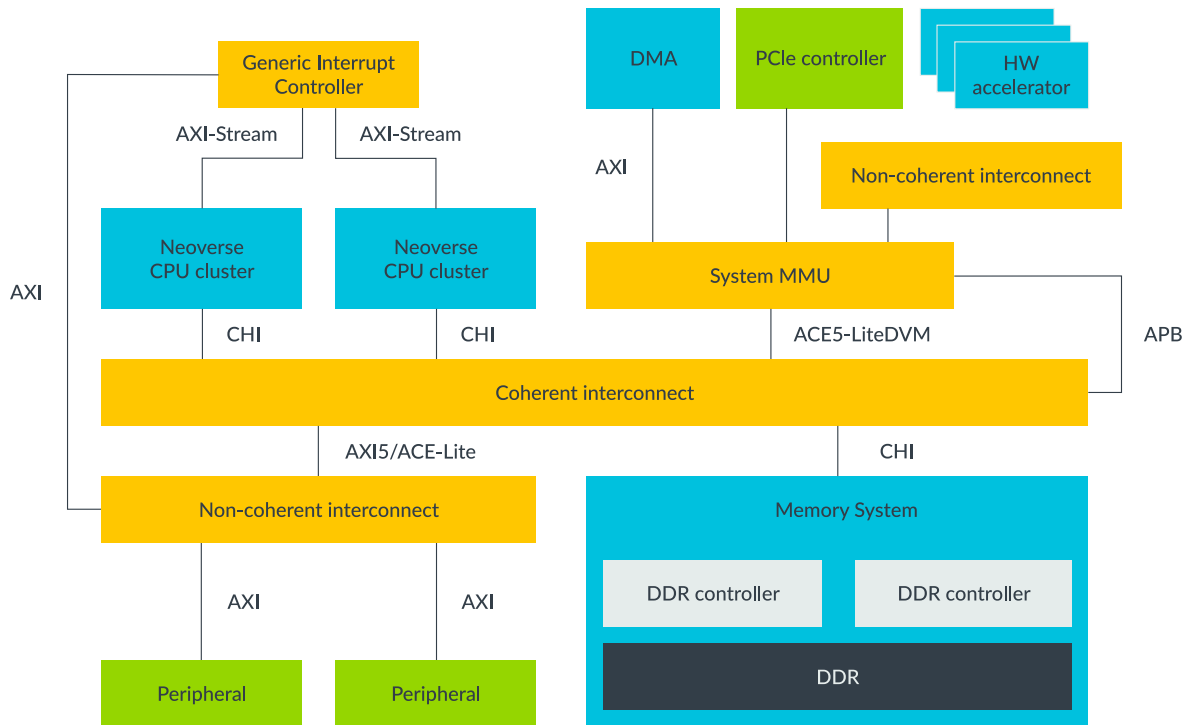

Where is AMBA used?

AMBA simplifies the development of designs with multiple processors and large numbers of controllers and peripherals. However, the scope of AMBA has increased over time, going far beyond just microcontroller devices.

Today, AMBA is widely used in a range of ASIC and SoC parts. These parts include applications processors that are used in devices like IoT subsystems, smartphones, and networking SoCs.

Why use AMBA?

AMBA provides several benefits:

- **Efficient IP reuse:** IP reuse is an essential component in reducing SoC development costs and timescales. AMBA specifications provide the interface standard that enables IP reuse. Therefore, thousands of SoCs, and IP products, are using AMBA interfaces.
- **Flexibility:** AMBA offers the flexibility to work with a range of SoCs. IP reuse requires a common standard while supporting a wide variety of SoCs with different power, performance, and area requirements. Arm offers a range of interface specifications that are optimized for these different requirements.
- **Compatibility:** A standard interface specification, like AMBA, allows compatibility between IP components from different design teams or vendors.
- **Support:** AMBA is well supported. It is widely implemented and supported throughout the semiconductor industry, including support from third-party IP products and tools.

Bus interface standards like AMBA, are differentiated through the performance that they enable. The two main characteristics of bus interface performance are:

- **Bandwidth:** The rate at which data can be driven across the interface. In a synchronous system, the maximum bandwidth is limited by the product of the clock speed and the width of the data bus.
- **Latency:** The delay between the initiation and completion of a transaction. In a burst-based system, the latency figure often refers to the completion of the first transfer rather than the entire burst.

The efficiency of your interface depends on the extent to which it achieves the maximum bandwidth with zero latency.

How has AMBA evolved?

AMBA has evolved over the years to meet the demands of processors and new technologies, as shown in the following diagram:

Figure 2-2: Key AMBA specifications

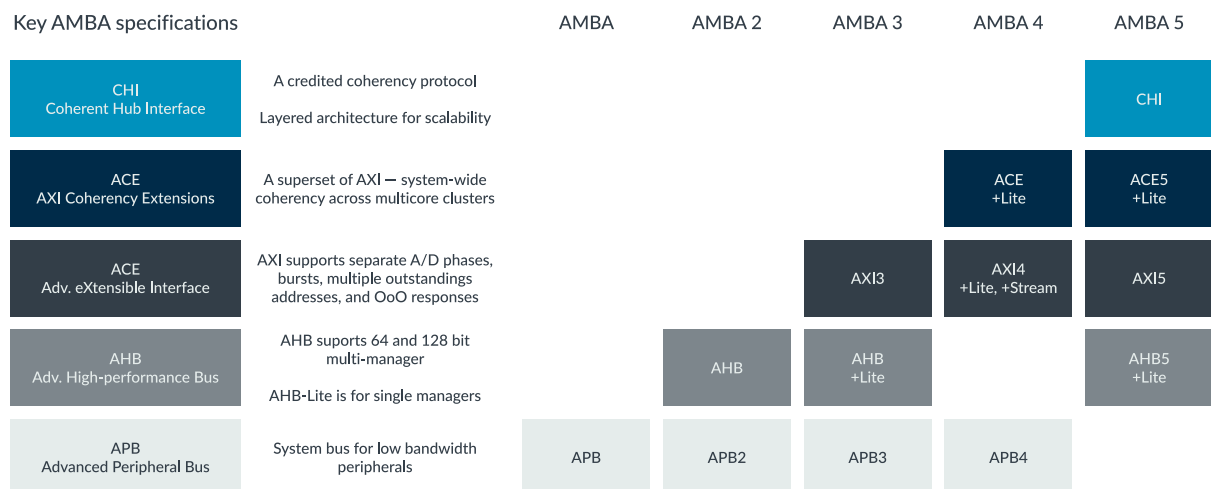

AMBA

Arm introduced AMBA in the late 1990s. The first AMBA buses were the Advanced System Bus (ASB) and the Advanced Peripheral Bus (APB). ASB has been superseded by more recent protocols, while APB is still widely used today.

APB is designed for low-bandwidth control accesses, for example, register interfaces on system peripherals. This bus has a simple address and data phase and a low complexity signal list.

AMBA 2

In 1999, AMBA 2 added the AMBA High-performance Bus (AHB), which is a single clock-edge protocol. A simple transaction on the AHB consists of an address phase and a subsequent data phase. Access to the target device is controlled through a MUX, admitting access to one manager at a time. AHB is pipelined for performance, while APB is not pipelined for design simplicity.

AMBA 3

In 2003, Arm introduced the third generation, AMBA 3, which includes ATB and AHB-Lite.

Advanced Trace Bus (ATB), is part of the CoreSight on-chip debug and trace solution.

AHB-Lite is a subset of AHB. This subset simplifies the design for a bus with a single manager.

Advanced eXtensible Interface (AXI), the third generation of AMBA interface defined in the AMBA 3 specification, is targeted at high performance, high clock frequency system designs. AXI includes features that make it suitable for high-speed submicrometer interconnect.

AMBA 4

In 2010, the AMBA 4 specifications were introduced, starting with AMBA 4 AXI4 and then AMBA 4 AXI Coherency Extensions (ACE) in 2011.

ACE extends AXI with additional signaling introducing system-wide coherency. This system-wide coherency allows multiple processors to share memory and enables technology like big.LITTLE processing. At the same time, the ACE-Lite protocol enables one-way coherency. One-way coherency enables a network interface to read from the caches of a fully coherent ACE processor.

The AXI4-Stream protocol is designed for unidirectional data transfers from manager to subordinate with reduced signal routing, which is ideal for implementation in FPGAs.

AMBA 5

In 2014, the AMBA 5 Coherent Hub Interface (CHI) specification was introduced, with a redesigned high-speed transport layer and features designed to reduce congestion. There have been several editions of the CHI protocol, and each new version adds new features.

In 2016, the AHB-Lite protocol was updated to AHB5, to complement the Armv8-M architecture, and extend the TrustZone security foundation from the processor to the system.

In 2019, the AMBA Adaptive Traffic Profiles (ATP) was introduced. ATP complements the existing AMBA protocols and is used for modeling high-level memory access behavior in a concise, simple, and portable way.

AXI5, ACE5 and ACE5-Lite extend prior generations, to include a number of performance and scalability features to align with and complement AMBA CHI. Some of the new features and options include:

- Support for high frequency, non-blocking coherent data transfer between many processors.
- A layered model to allow separation of communication and transport protocols for flexible topologies, such as a cross-bar, ring, mesh or ad hoc.
- Cache stashing to allow accelerators or IO devices to stash critical data within a CPU cache for low latency access.
- Far atomic operations enable the interconnect to perform high-frequency updates to shared data.
- End-to-end data protection and poisoning signalling.

3. AXI protocol overview

AXI is an interface specification that defines the interface of IP blocks, rather than the interconnect itself.

The following diagram shows how AXI is used to interface an interconnect component:

Figure 3-1: AXI interface

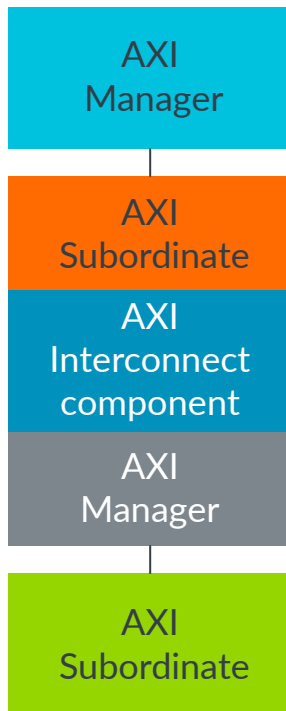

There are only two AXI interface types, manager and subordinate. These interface types are symmetrical. All AXI connections are between manager interfaces and subordinate interfaces.

AXI interconnect interfaces contain the same signals, which makes integration of different IP relatively simple. The previous diagram shows how AXI connections join manager and subordinate interfaces. The direct connection gives maximum bandwidth between the manager and subordinate components with no extra logic. And with AXI, there is only a single protocol to validate.

AXI in a multi-manager system

The following diagram shows a simplified example of an SoC system, which is composed of managers, subordinates, and the interconnect that links them all:

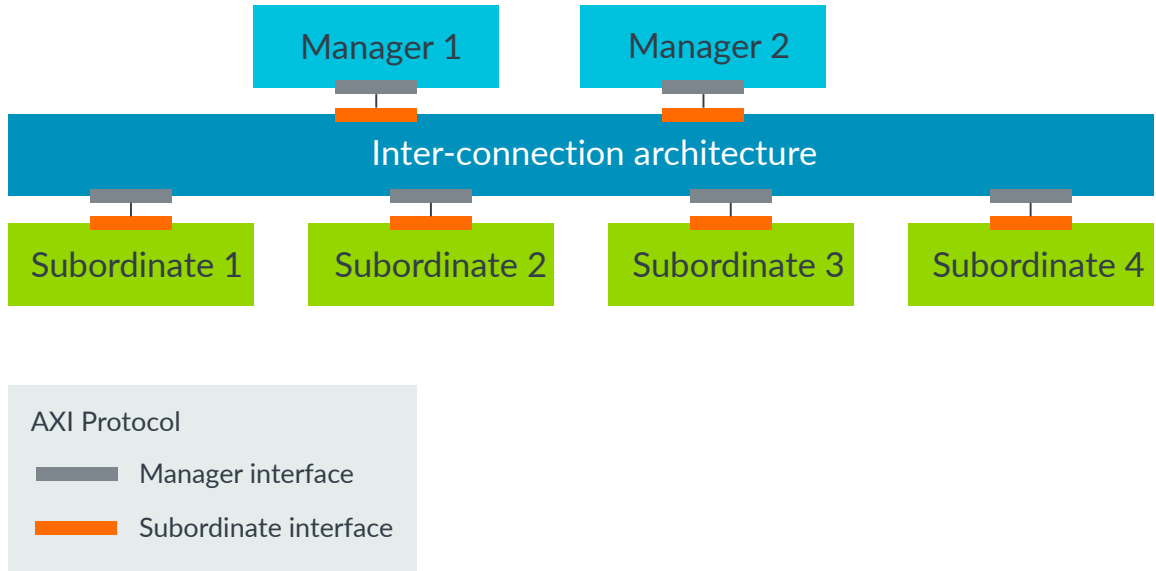
Figure 3-2: Multi master high-level

An Arm processor is an example of a manager, and a simple example of a subordinate is a memory controller.

The AXI protocol defines the signals and timing of the point-to-point connections between manager and subordinates.



The AXI protocol is a point-to-point specification, not a bus specification. Therefore, it describes only the signals and timing between interfaces.

The previous diagram shows that each AXI manager interface is connected to a single AXI subordinate interface. Where multiple managers and subordinates are involved, an interconnect fabric is required. This interconnect fabric also implements subordinate and manager interfaces, where the AXI protocol is implemented.

The following diagram shows that the interconnect is a complex element that requires its own AXI manager and subordinate interfaces to communicate with external function blocks:

Figure 3-3: Multi master interconnect

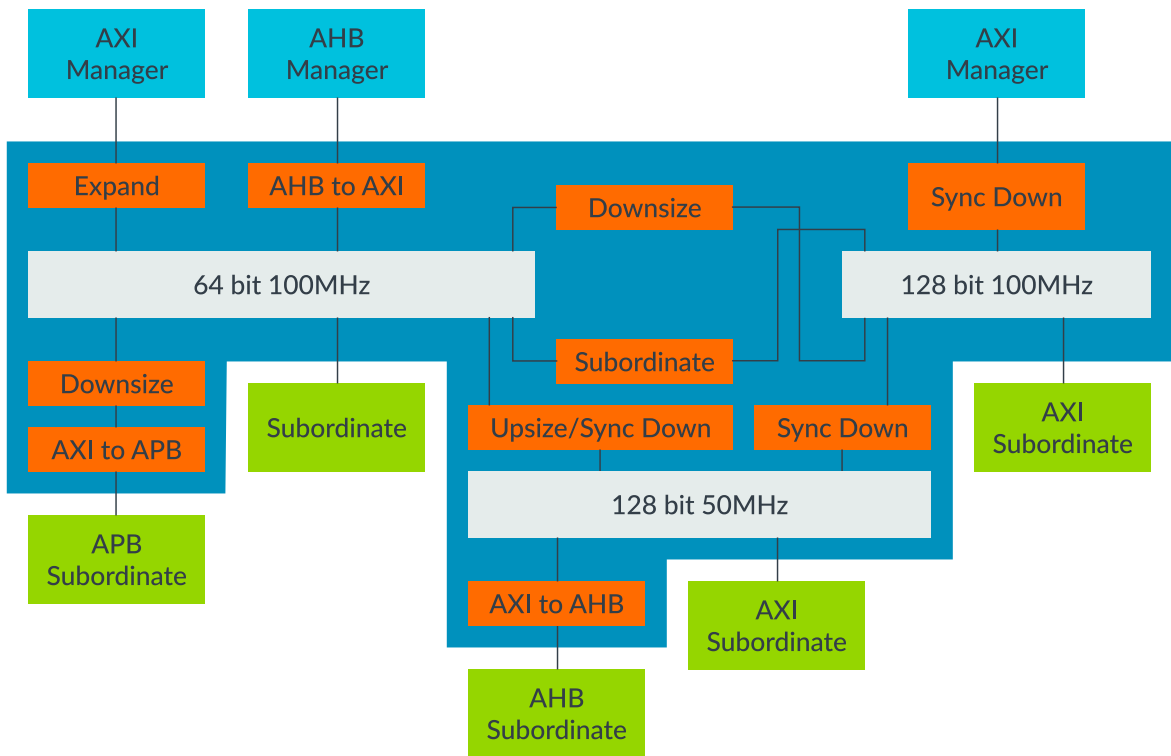

The following diagram shows an example of an SoC with various processors and function blocks:

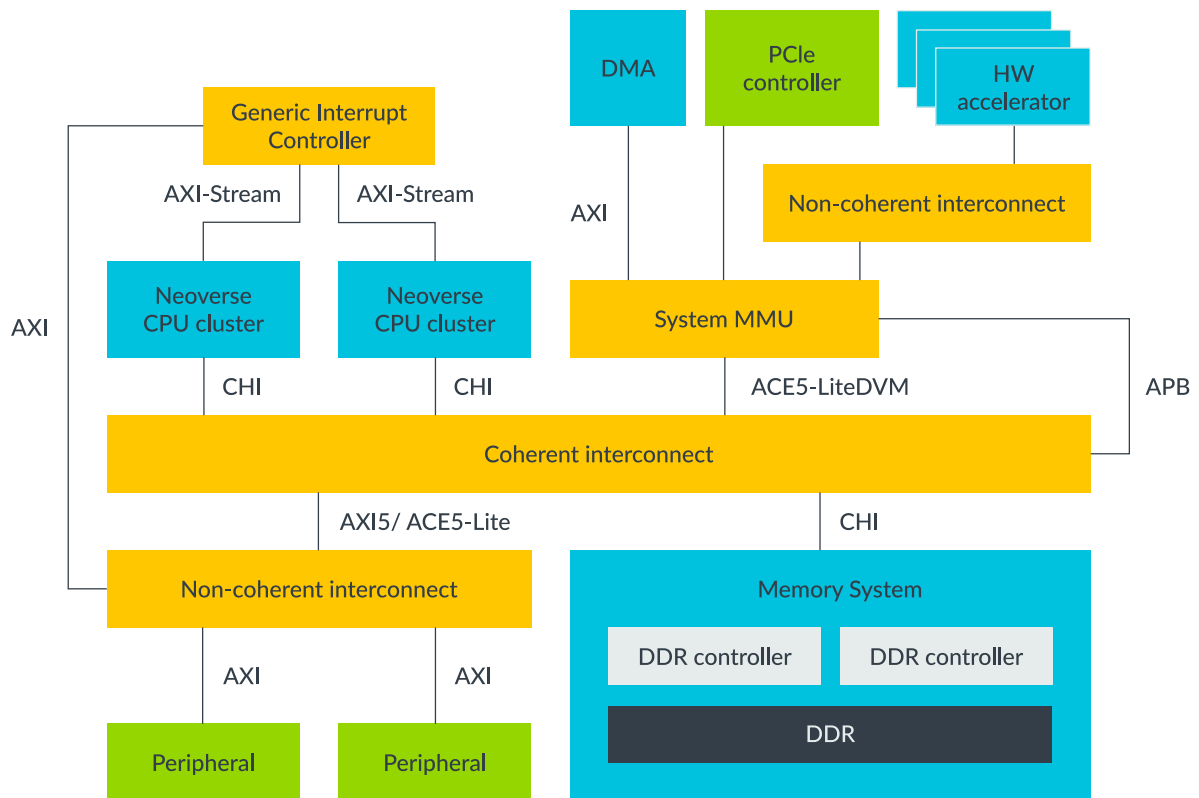
Figure 3-4: System diagram

The previous diagram shows all the connections where AXI is used. You can see that AXI3 and AXI4 are used within the same SoC, which is common practice. In such cases, the interconnect performs the protocol conversion between the different AXI interfaces.

AXI channels

The AXI specification describes a point-to-point protocol between two interfaces: a manager and a subordinate. The following diagram shows the five main channels that each AXI interface uses for communication:

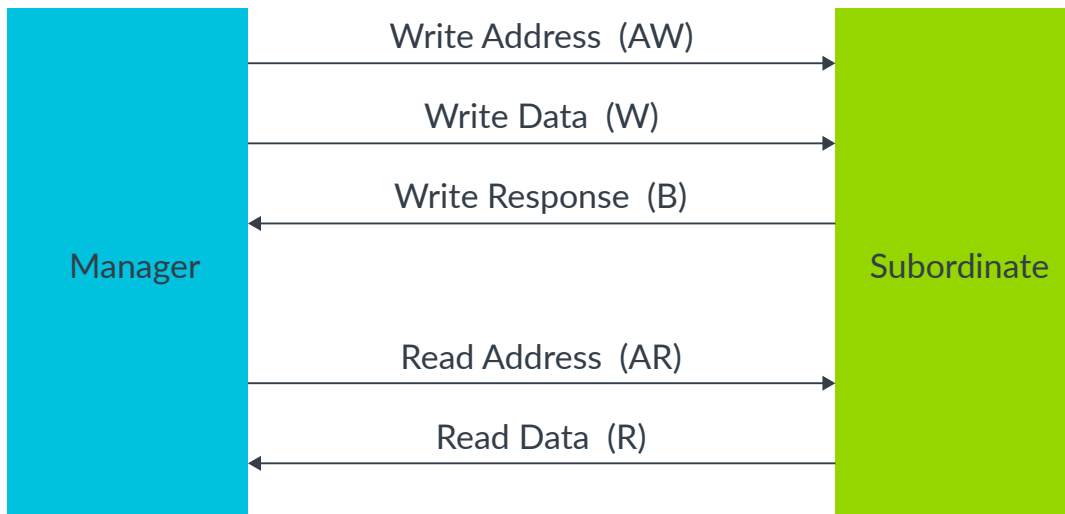
Figure 3-5: Axi channels

Write operations use the following channels:

- The manager sends an address on the Write Address (AW) channel and transfers data on the Write Data (W) channel to the subordinate.
- The subordinate writes the received data to the specified address. Once the subordinate has completed the write operation, it responds with a message to the manager on the Write Response (B) channel.

Read operations use the following channels:

- The manager sends the address it wants to read on the Read Address (AR) channel.
- The subordinate sends the data from the requested address to the manager on the Read Data (R) channel. The subordinate can also return an error message on the Read Data (R) channel. An error occurs if, for example, the address is not valid, or the data is corrupted, or the access does not have the right security permission.



Each channel is unidirectional, so a separate Write Response channel is needed to pass responses back to the manager. However, there is no need for a Read Response channel, because a read response is passed as part of the Read Data channel.

Using separate address and data channels for read and write transfers helps to maximize the bandwidth of the interface. There is no timing relationship between the groups of read and write channels. This means that a read sequence can happen at the same time as a write sequence.

Each of these five channels contains several signals, and all these signals in each channel have the prefix as follows:

- AW for signals on the Write Address channel
- AR for signals on the Read Address channel
- W for signals on the Write Data channel
- R for signals on the Read Data channel
- B for signals on the Write Response channel



B stands for buffered, because the response from the subordinate happens after all writes have completed.

Main AXI features

The AXI protocol has several key features that are designed to improve bandwidth and latency of data transfers and transactions, as you can see here:

- Independent read and write channels: AXI supports two different sets of channels, one for write operations, and one for read operations. Having two independent sets of channel helps to improve the bandwidth performances of the interfaces. This is because read and write operations can happen at the same time.
- Multiple outstanding addresses: AXI allows for multiple outstanding addresses. This means that a manager can issue transactions without waiting for earlier transactions to complete. This can improve system performance because it enables parallel processing of transactions.
- No strict timing relationship between address and data operations: With AXI, there is no strict timing relationship between the address and data operations. This means that, for example, a manager could issue a write address on the Write Address channel, but there is no time requirement for when the manager has to provide the corresponding data to write on the Write Data channel.
- Support for unaligned data transfers: For any burst that is made up of data transfers wider than one byte, the first bytes accessed can be unaligned with the natural address boundary. For example, a 32-bit data packet that starts at a byte address of $0x1002$ is not aligned to the natural 32-bit address boundary.
- Out-of-order transaction completion: Out-of-order transaction completion is possible with AXI. The AXI protocol includes transaction identifiers, and there is no restriction on the completion of transactions with different ID values. This means that a single physical port can support out-of-order transactions by acting as several logical ports, each of which handles its transactions in order.
- Burst transactions based on start address: AXI managers only issue the starting address for the first transfer. For any following transfers, the subordinate will calculate the next transfer address based on the burst type.

4. Channel transfers and transactions

This section explains the handshake principle for AXI channels, and shows how the handshake is the underpinning mechanism for all read and write transactions.

Channel handshake

The AXI4 protocol defines five different channels, as described in [AXI channels](#). All of these channels share the same handshake mechanism that is based on the VALID and READY signals, as shown in the following diagram:

Figure 4-1: Handshake

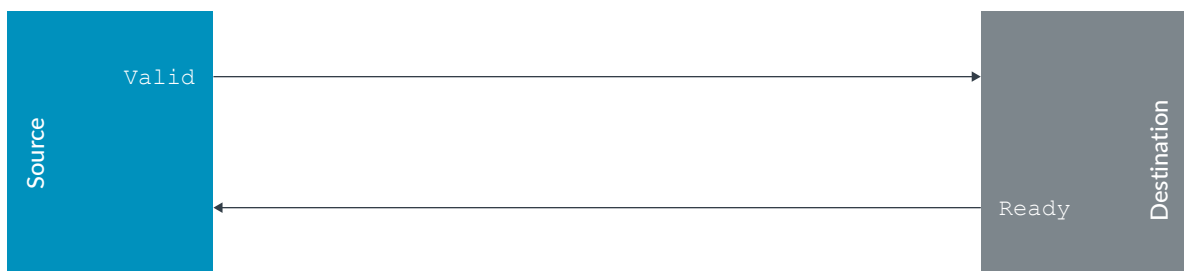

The VALID signal goes from the source to the destination, and READY goes from the destination to the source.

Whether the source or destination is a manager or subordinate depends on which channel is being used. For example, the manager is a source for the Read Address channel, but a destination for the Read Data channel.

The source uses the VALID signal to indicate when valid information is available. The VALID signal must remain asserted, meaning set to high, until the destination accepts the information. Signals that remain asserted in this way are called sticky signals.

The destination indicates when it can accept information using the READY signal. The READY signal goes from the channel destination to the channel source.

This mechanism is not an asynchronous handshake, and requires the rising edge of the clock for the handshake to complete.

Differences between transfers and transactions

When designing interconnect fabric, you must know the capabilities of the managers and subordinates that are being connected. Knowing this information lets you include sufficient buffering, tracking, and decode logic to support the various data transfer ordering possibilities that allow performance improvements in faster devices.

Using standard terminology makes understanding the interactions between connected components easier. AXI makes a distinction between transfers and transactions:

- A transfer is a single exchange of information, with one VALID and READY handshake.
- A transaction is an entire burst of transfers, containing an address transfer, one or more data transfers, and, for write sequences, a response transfer.

Channel transfer examples

This section examines some examples of possible handshakes between source and destination. It shows several possible combinations of VALID and READY sequences that conform to the AXI protocol specifications.

In the first example, shown in the following diagram, we have a clock signal, followed by an information bus, and then the VALID and READY signals:

Figure 4-2: Example transfer

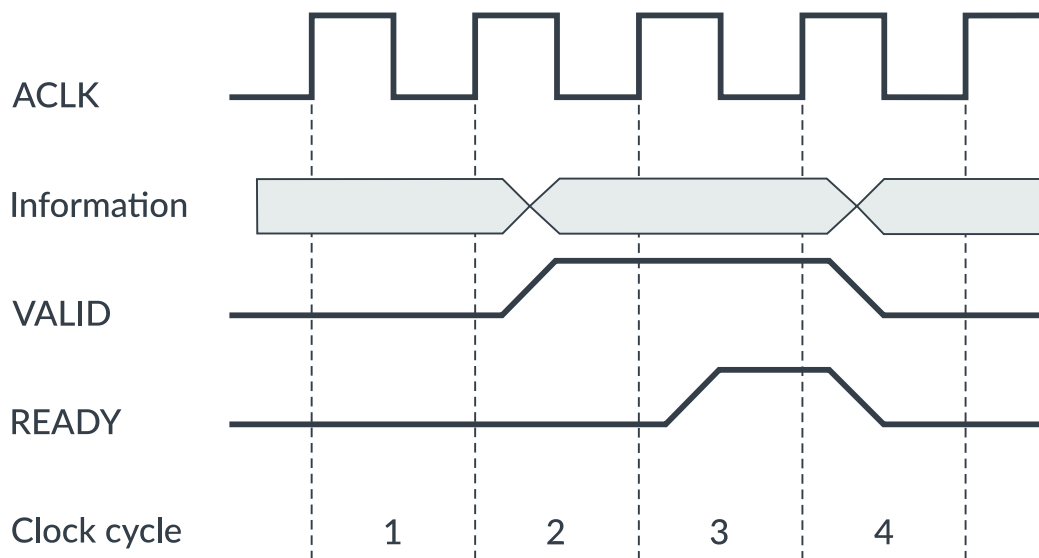

This example has the following sequence of events:

1. In clock cycle 2, the VALID signal is asserted, indicating that the data on the information channel is valid.
2. In clock cycle 3, the following clock cycle, the READY signal is asserted.
3. The handshake completes on the rising edge of clock cycle 4, because both READY and VALID signals are asserted.

The following diagram shows another example:

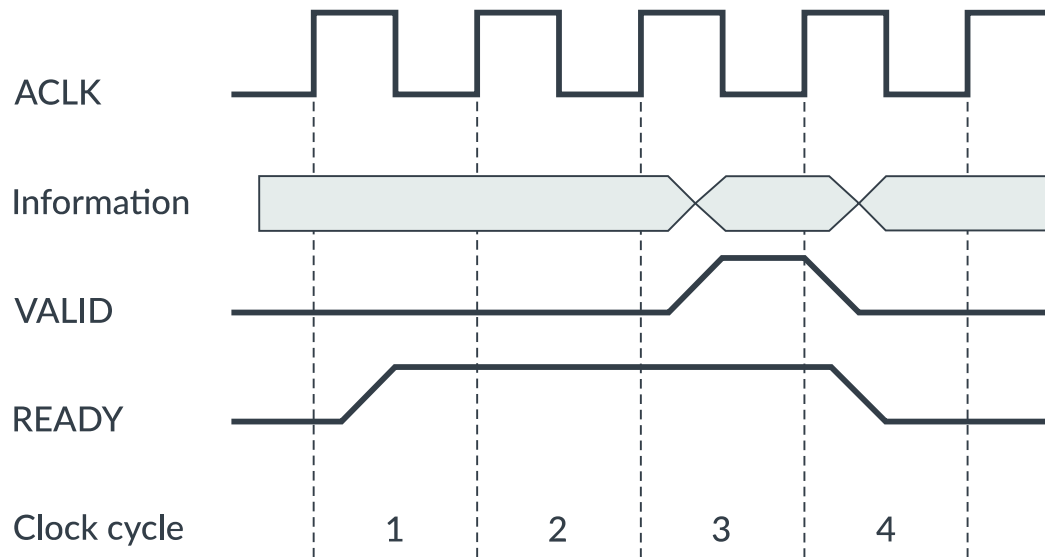
Figure 4-3: Example transfer

This example has the following sequence of events:

1. In clock cycle 1, the READY signal is asserted.
2. The VALID signal is not asserted until clock cycle 3.
3. The handshake completes on the rising edge of clock cycle 4, when both VALID and READY are asserted.

The final example shows both VALID and READY signals being asserted during the clock cycle 3, as seen in the following diagram:

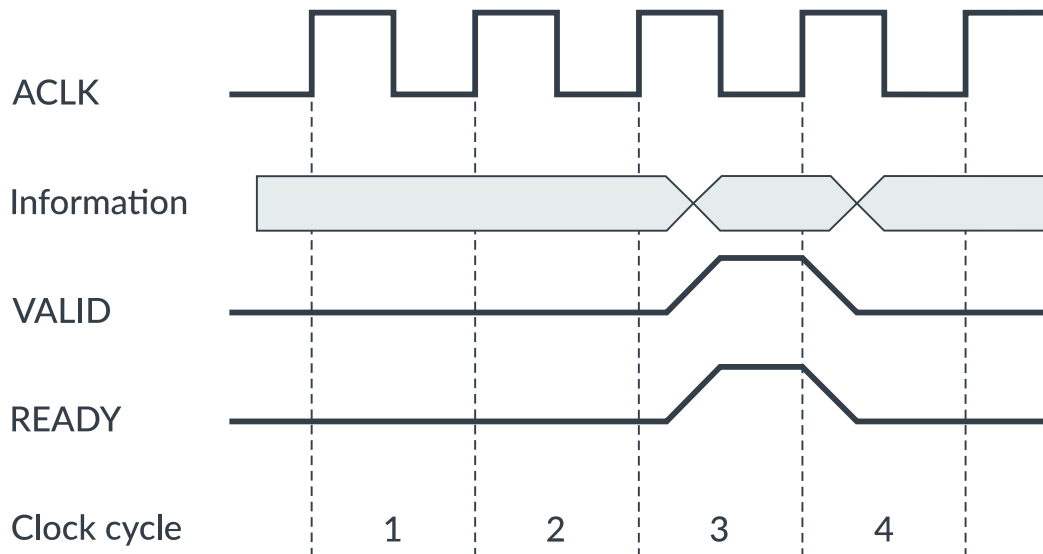
Figure 4-4: Example transfer

Again, the handshake completes on the rising edge of clock cycle 4, when both VALID and READY are asserted.

In all three examples, information is passed down the channel when READY and VALID are asserted on the rising edge of the clock signal.

Read and write handshakes must adhere to the following rules:

- A source cannot wait for READY to be asserted before asserting VALID.
- A destination can wait for VALID to be asserted before asserting READY.

These rules mean that READY can be asserted before or after VALID, or even at the same time.

Write transaction: single data item

This section describes the process of a write transaction for a single data item, and the different channels that are used to complete the transaction.

This write transaction involves the following channels:

- Write Address (AW)
- Write (W)
- Write Response (B)

First, there is a handshake on the Write Address (AW) channel, as shown in the following diagram:

Figure 4-5: Write single

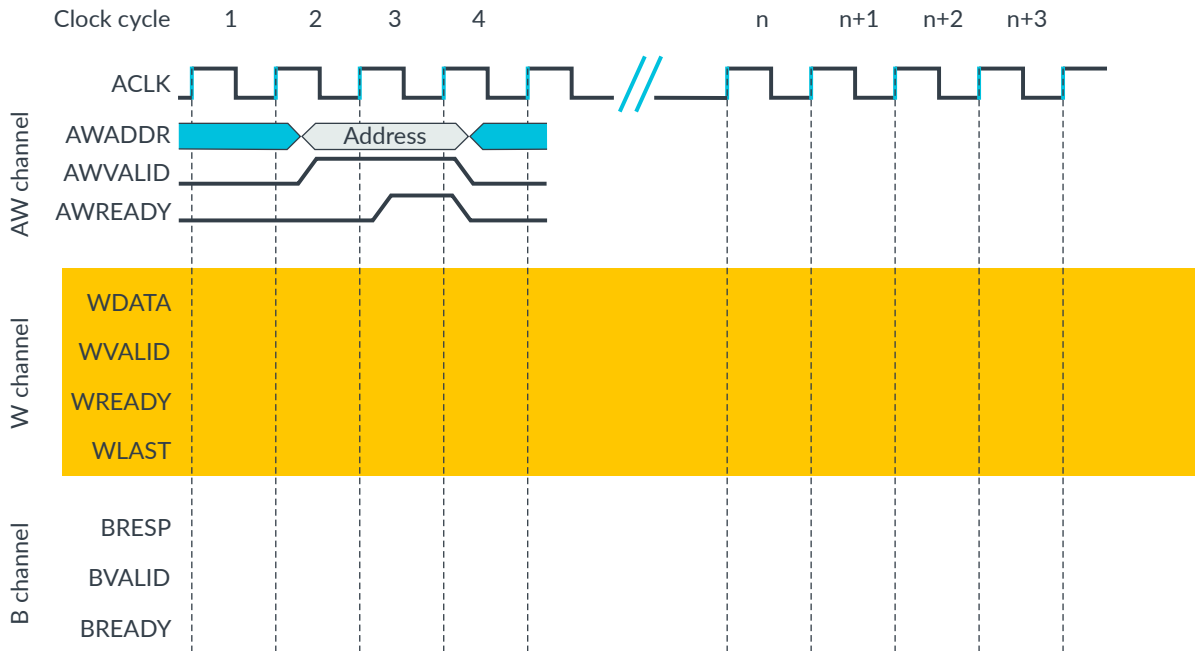

This handshake is where the manager communicates the address of the write to the subordinate. The handshake has the following sequence of events:

1. The manager puts the address on AWADDR and asserts AWVALID in clock cycle 2.
2. The subordinate asserts AWREADY in clock cycle 3 to indicate its ability to receive the address value.
3. The handshake completes on the rising edge of clock cycle 4.

After this first handshake, the manager transfers the data to the subordinate on the Write (W) channel, as shown in the following diagram:

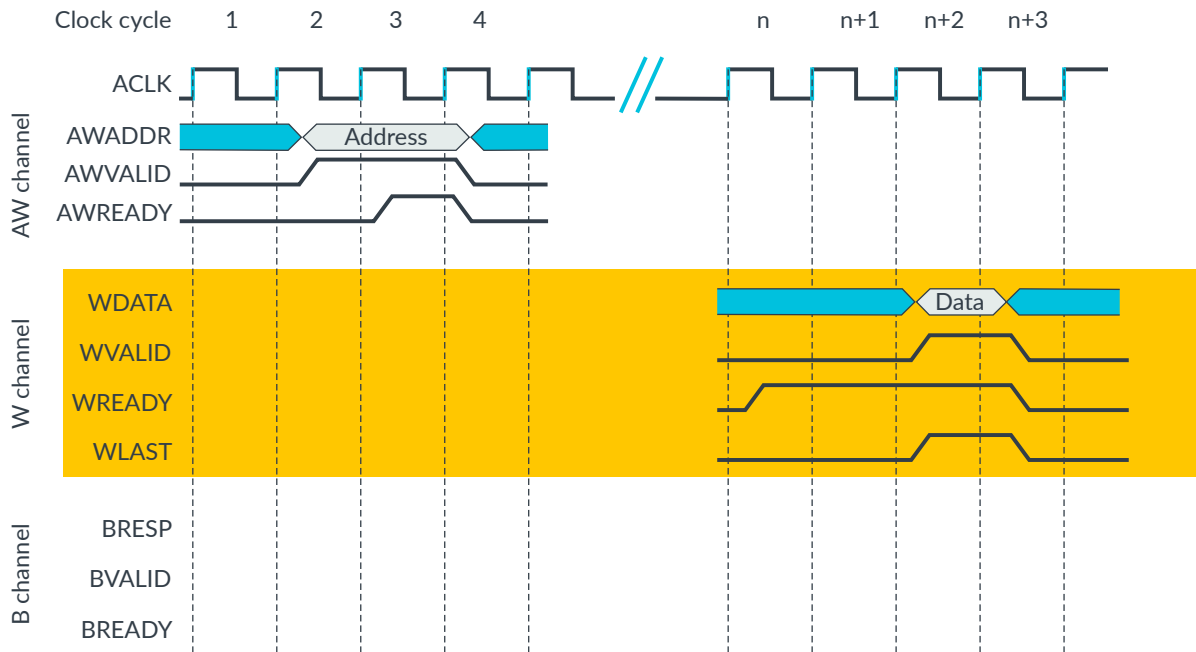
Figure 4-6: Write single

The data transfer has the following sequence of events:

1. The subordinate is waiting for data with WREADY set to high in clock cycle n.
2. The manager puts the data on the WDATA bus and asserts WVALID in clock cycle n+2.
3. The handshake completes on the rising edge of clock cycle n+3

Finally, the subordinate uses the Write Response (B) channel, to confirm that the write transaction has completed once all WDATA has been received. This response is shown in the following diagram:

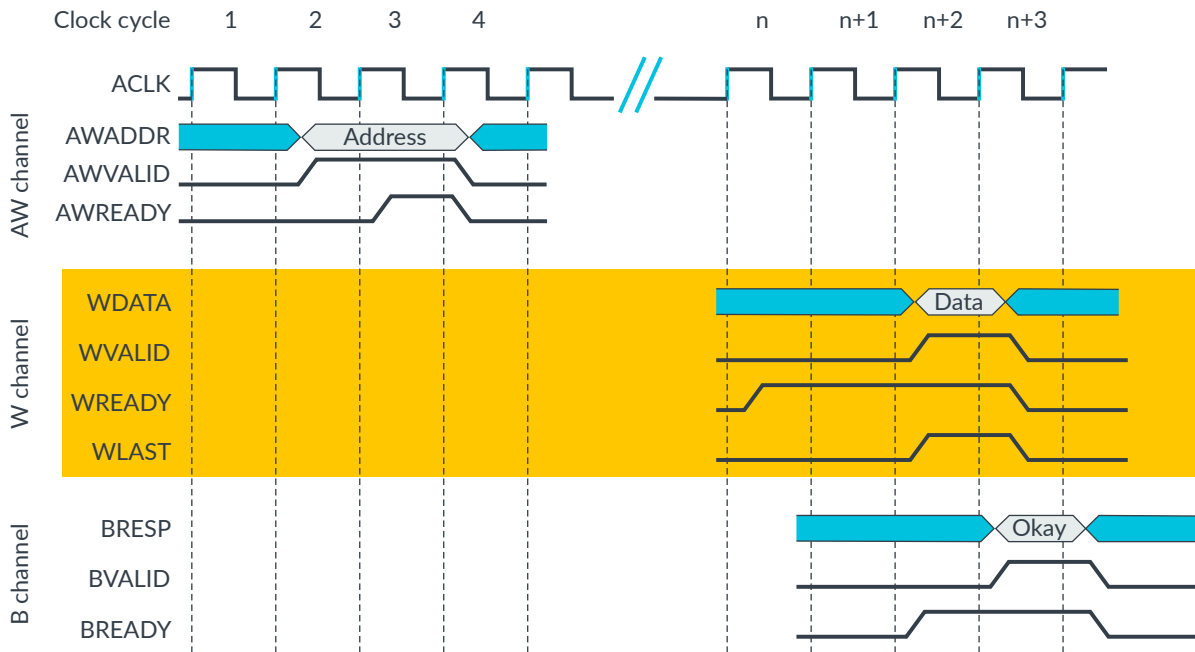
Figure 4-7: Write single

The write response has the following sequence of events:

1. The manager asserts BREADY.
2. The subordinate drives BRESP to indicate success or failure of the write transaction, and asserts BVALID.

The handshake completes on the rising edge of clock cycle n+4.

Write transaction: multiple data items

AXI is a burst-based protocol, which means that it is possible to transfer multiple data in a single transaction. We can transfer a single address on the AW channel to transfer multiple data, with associated burst width and length information.

The following diagram shows an example of a multiple data transfer:

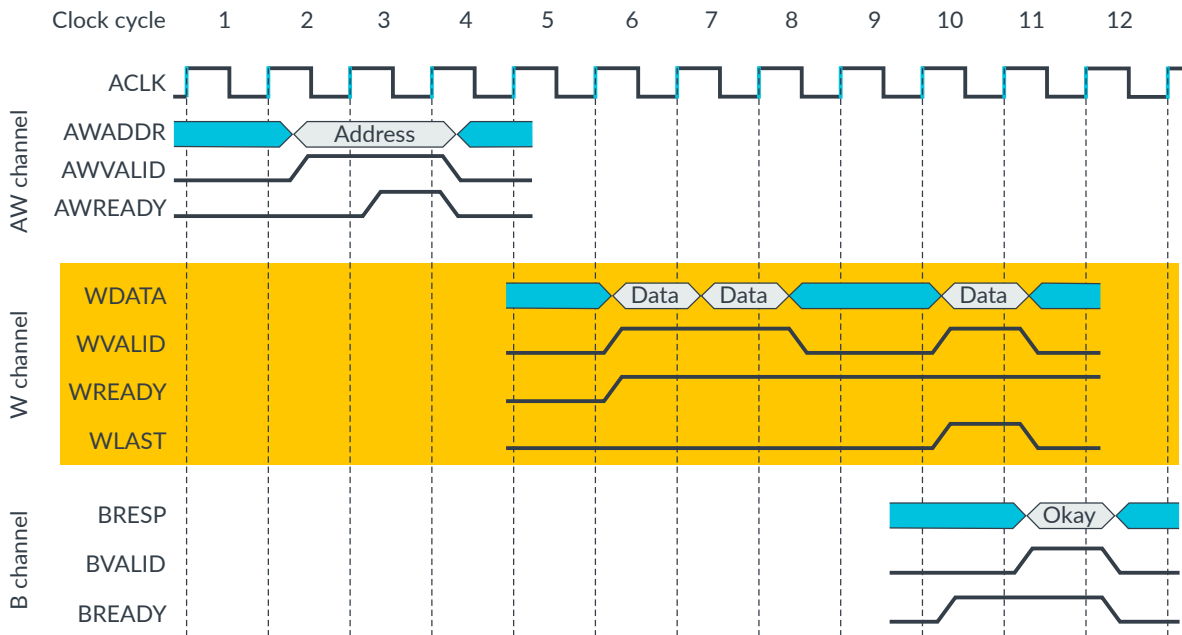
Figure 4-8: Write multiple

In this case, the AW channel indicates a sequence of three transfers, and on the W channel, we see three data transfers.

The manager drives the WLAST high to indicate the final WDATA. This means that the subordinate can either count the data transfers or just monitor WLAST.

Once all WDATA transfers are received, the subordinate gives a single BRESP value on the B channel. One single BRESP covers the entire burst. If the subordinate decides that any of the transfers contain an error, it must wait until the entire burst has completed before it informs the manager that an error occurred.

Read transaction: single data item

This section looks in detail at the process of a read transaction for a single data item, and the different channels used to complete the transaction.

This write transaction involves the following channels:

- Read Address (AR)
- Read (R)

First, there is a handshake on the Read Address (AR) channel, as shown in the following diagram:

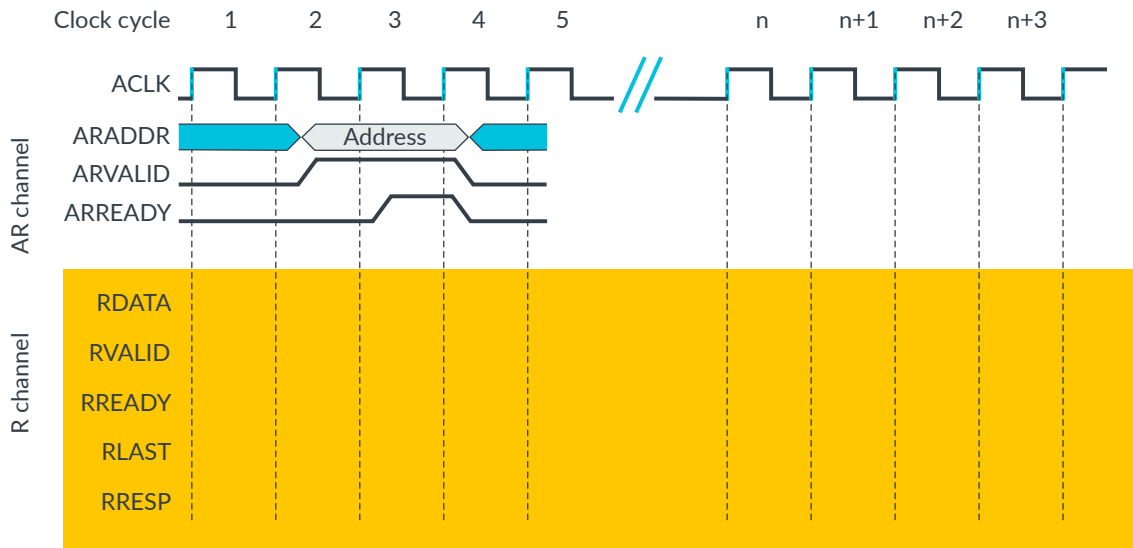
Figure 4-9: Read single

The handshake has the following sequence of events:

1. In clock cycle 2, the manager communicates the address of the read to the subordinate on ARADDR and asserts ARVALID.
2. In clock cycle 3, the subordinate asserts ARREADY to indicate that it is ready to receive the address value.

The handshake completes on the rising edge of clock cycle 4.

Next, on the Read (R) channel, the subordinate transfers the data to the manager. The following diagram shows the data transfer process:

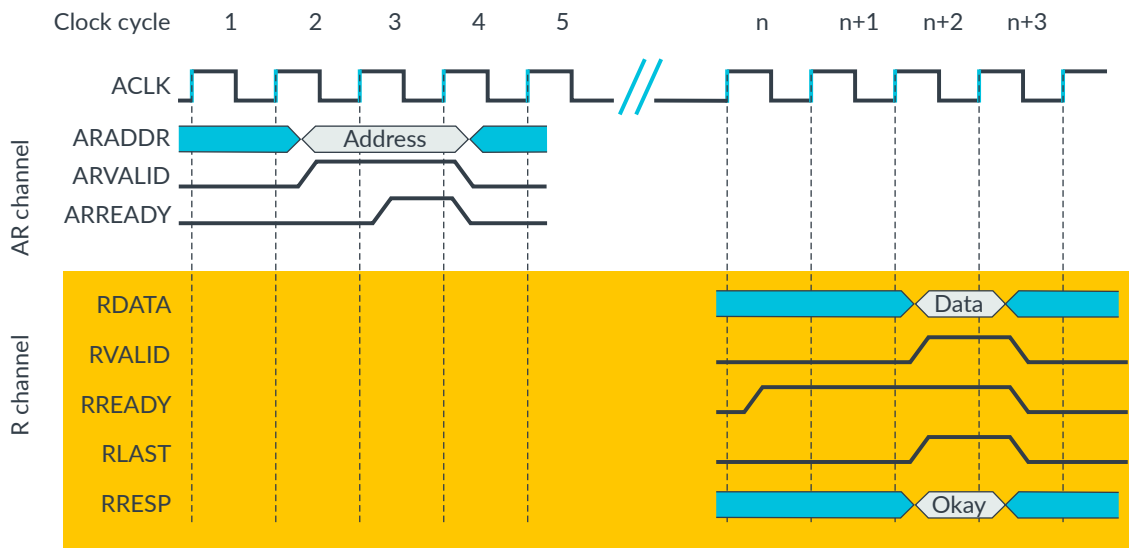
Figure 4-10: Read single

The data transfer handshake has the following sequence of events:

1. In clock cycle n, the manager indicates that it is waiting to receive the data by asserting RREADY.
2. The subordinate retrieves the data and places it on RDATA in clock cycle n+2. In this case, because this is a single data transaction, the subordinate also sets the RLAST signal to high. At the same time, the subordinate uses RRESP to indicate the success or failure of the read transaction to the manager, and asserts RVALID.
3. Because RREADY is already asserted by the manager, the handshake completes on the rising edge of clock cycle n+3.

Read transaction: multiple data items

The AXI protocol also allows a read burst of multiple data transfer in the same transaction. This is similar to the write burst that is described in [Write transaction: multiple data items](#).

The following diagram shows an example of a burst read transfer:

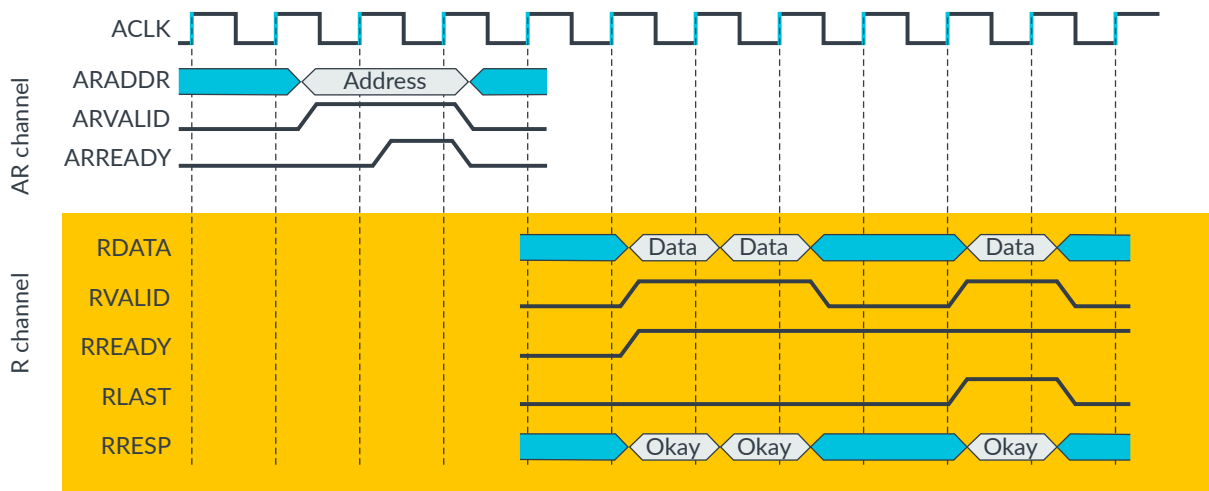
Figure 4-11: Read multiple

In this example, we transfer a single address on the AR channel to transfer multiple data items, with associated burst width and length information.

Here, the AR channel indicates a sequence of three transfers, therefore on the R channel, we see three data transfers from the subordinate to the manager.

On the R channel, the subordinate transfers the data to the manager. In this example, the manager is waiting for data as shown by RREADY set to high. The subordinate drives valid RDATA and asserts RVALID for each transfer.

One difference between a read transaction and a write transaction is that for a read transaction there is an RRESP response for every transfer in the transaction. This is because, in the write transaction, the subordinate has to send the response as a separate transfer on the B channel. In the read transaction, the subordinate uses the same channel to send the data back to the manager and to indicate the status of the read operation.

If an error is indicated for any of the transfers in the transaction, the full indicated length of the transaction must still be completed. There is no such thing as early burst termination.

Active transactions

Active transactions are also known as outstanding transactions.

An active read transaction is a transaction for which the read address has been transferred, but the last read data has not yet been transferred at the current point in time.

With reads, the data must come after the address, so there is a simple reference point for when the transaction starts. This is shown in the following diagram:

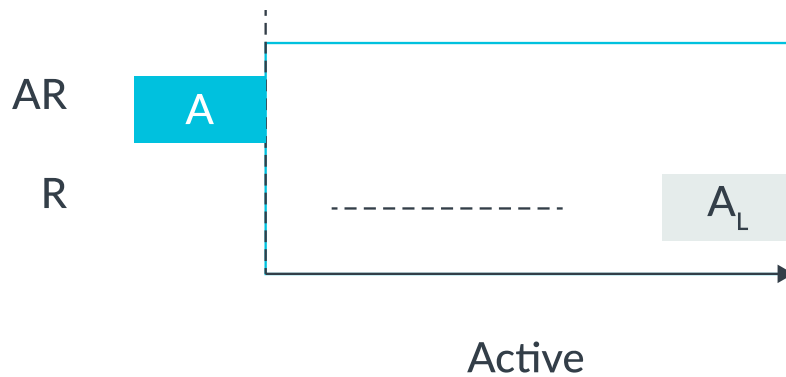
Figure 4-12: Active read

For write transactions, the data can come after the address, but leading write data is also allowed. The start of a write transaction can therefore be either of the following:

- The transfer of the write address
- The transfer of leading write information

Therefore, an active write transaction is a transaction for which the write address or leading write data has been transferred, but the write response has not yet been transferred.

The following diagram shows an active write transaction where the write address has been transferred, but the write response has not yet been transferred:

Figure 4-13: Active write

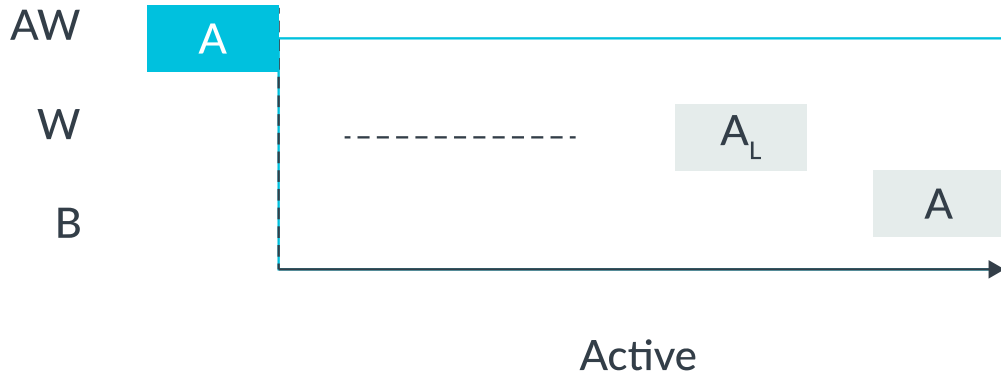

The following diagram shows an active write transaction where the leading write data has been transferred, but the write response has not yet been transferred:

Figure 4-14: Active write

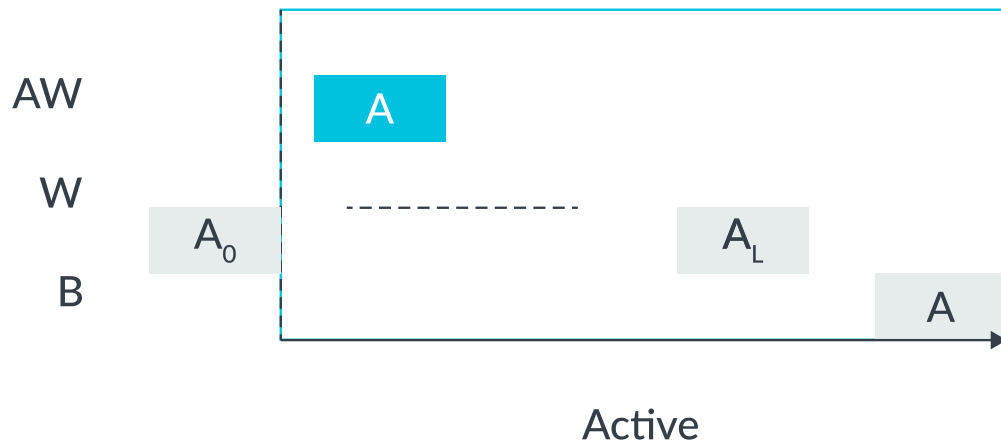

5. Channel signals

This section introduces the main AXI signals and attributes, and explains how they are used to improve system performance. It focuses on AXI3 and AXI4; AXI5 will be covered in a future iteration.

The AXI protocol defines five channels: three for write signals, and two for read signals.

Write channel signals

The channels used for a write transaction are:

- Write Address
- Write Data
- Write Response

The following table shows the Write Address channel signals:

Write Address (AW) channel signals	AXI version
AWVALID	AXI3 and AXI4
AWREADY	AXI3 and AXI4
AWADDR[31:0]	AXI3 and AXI4
AWSIZE[2:0]	AXI3 and AXI4
AWBURST[1:0]	AXI3 and AXI4
AWCACHE[3:0]	AXI3 and AXI4
AWPROT[2:0]	AXI3 and AXI4
AWID[x:0]	AXI3 and AXI4
AWLEN[3:0]	AXI3 only
AWLEN[7:0]	AXI4 only
AWLOCK[1:0]	AXI3 only
AWLOCK	AXI4 only
AWQOS[3:0]	AXI4 only
AWREGION[3:0]	AXI4 only
AWUSER[x:0]	AXI4 only

The following table shows the Write Data channel signals:

Write Data (W) channel signals	AXI version
WVALID	AXI3 and AXI4
WREADY	AXI3 and AXI4
WLAST	AXI3 and AXI4
WDATA[x:0]	AXI3 and AXI4
WSTRB[x:0]	AXI3 and AXI4

Write Data (W) channel signals	AXI version
WID[x:0]	AXI3 only
WUSER[x:0]	AXI4 only

The following table shows the Write Response channel signals:

Write response (B) channel signals	AXI version
BWVALID	AXI3 and AXI4
BWREADY	AXI3 and AXI4
BRESP[1:0]	AXI3 and AXI4
BID[x:0]	AXI3 and AXI4
BUSER[x:0]	AXI4 only

All the signals in each channel have the same prefix:

- AW for the Write Address channel
- W for the Write Data channel
- B for the Write Response channel

There are some differences between the AXI3 protocol and the AXI4 protocol for the write channels:

- For the write address channel, the AWLEN signal is wider for the AXI4 protocol. Therefore, AXI4 is able to generate longer bursts than AXI3.
- AXI4 reduces the AWLOCK signal to a single bit to only accommodate exclusive transfers because locked transfers are not supported.
- AXI4 adds the AWQOS signal to the AW channel. This signal supports the concept of quality of service (QoS) in the AXI4 protocol.
- AXI4 adds the AWREGION signal to the AW channel. This signal supports subordinate regions which allow for multiple logical interfaces from a single physical subordinate interface.
- AXI4 removes the WID signal from the W channel. This is because write data reordering is no longer allowed.
- AXI4 adds user-defined signals to each channel.

Read channel signals

The channels used for a read transaction are:

- Read Address
- Read Data

The following table shows the Read Address channel signals:

Read Address (AR) channel signals	AXI version
ARVALID	AXI3 and AXI4
AREADY	AXI3 and AXI4

Read Address (AR) channel signals	AXI version
ARADDR[31:0]	AXI3 and AXI4
ARSIZE[2:0]	AXI3 and AXI4
ARBURST[1:0]	AXI3 and AXI4
ARCACHE[3:0]	AXI3 and AXI4
ARPROT[2:0]	AXI3 and AXI4
ARID[x:0]	AXI3 and AXI4
ARLEN[3:0]	AXI3 only
ARLEN[7:0]	AXI4 only
ARLOCK[1:0]	AXI3 only
ARLOCK	AXI4 only
ARQOS[3:0]	AXI4 only
ARREGION[3:0]	AXI4 only
ARUSER[x:0]	AXI4 only

The following table shows the Read Data channel signals:

Read Data (R) channel signals	AXI version
RVALID A	AXI3 and AXI4
RREADY A	AXI3 and AXI4
RLAST	AXI3 and AXI4
RDATA[x:0]	AXI3 and AXI4
RRESP[1:0]	AXI3 and AXI4
RID[x:0]]	AXI3 and AXI4
RUSER[x:0]	AXI4 only

All the signals in each channel have the same prefix:

- AR for the Read Address channel
- R for the Read Data channel

There are some differences between the AXI3 protocol and the AXI4 protocol for the read channels:

- For the AXI4 protocol, the read address length signal ARLEN is wider. Therefore, AXI4 is able to generate longer read bursts than AXI3.
- AXI4 reduces the ARLOCK signal to a single bit to only accommodate exclusive transfers because locked transfers are not supported.
- As with the write channel signals, the concepts of quality of service and subordinate regions apply to read transactions. These use the ARQOS and ARREGION signals in the AR channel.
- AXI4 adds user-defined signals to the two read channels.

Data size, length, and burst type

Each read and write transaction has attributes that specify the data length, size, and the burst signal attributes for that transaction.

In the following list of attributes, x stands for write and read, so they apply to both the Write Address channel and the Read Address channel:

- AxLEN describes the length of the transaction in the number of transfers.
 - For AXI3, AxLEN[3:0] has 4 bits, which specifies a range of 1-16 transfers in a transaction.
 - For AXI4, AxLEN[7:0] has 8 bits, which specifies a range of 1-256 data transfers in a transaction.
- AxSize[2:0] describes the maximum number of bytes to transfer in each data transfer. Three bits of encoding indicate 1, 2, 4, 8, 16, 32, 64, or 128 bytes per transfer.
- AxBURST[1:0] describes the burst type of the transaction: fixed, incrementing, or wrapping. The following table shows the different properties of these burst types:

Value	Burst type	Usage notes	Length (number of transfers)	Alignment
0x00	FIXED	Reads the same address repeatedly. Useful for FIFO s.	1-16	Fixed byte lanes only defined by start address and size.
0x01	INCR	Incrementing burst. The subordinate increments the address for each transfer in the burst from the address for the previous transfer. The incremental value depends on the size of the transfer, as defined by the AxSIZE attribute. Useful for block transfers.	AXI3: 1-16 AXI4: 1-256	Unaligned t ransfers are supported.
0x10	WRAP	Wrapping burst. Similar to an incrementing burst, except that if an upper address limit is reached, the address wraps around to a lower address. Commonly used for cache line accesses.	2, 4, 8, or 16	The start address must be aligned to the transfer size.
0x11	RESERVED	Not for use.		

Protection level support

AXI provides access permissions signals, AWPROT and ARPROT, that can protect against illegal transactions downstream in the system. For example, if a transaction does not have the correct level of protection, a memory controller could refuse read or write access by using these signals.

This is useful for security solutions like Arm TrustZone, where a processor has two separate states, Secure and Non-secure.

AxPROT defines three levels of access protection, as shown in the following diagram:

Figure 5-1: Protection levels

The AxPROT bit allocations specify the following attributes:

- AxPROT[0] (P) identifies an access as unprivileged or privileged:
 - 1 indicates privileged access.
 - 0 indicates unprivileged access.

Although some processors support multiple levels of privilege, the only distinction that AXI can provide is between privileged and unprivileged access.

- AxPROT[1] (NS) identifies an access as Secure or Non-secure:
 - 1 indicates a Non-secure transaction.
 - 0 indicates a Secure transaction.
- AxPROT[2] (I) indicates whether the transaction is an instruction access or a data access:
 - 1 indicates an instruction access.
 - 0 indicates a data access.

The AXI protocol defines this indication as a hint. It is not accurate in all cases, for example, where a transaction contains a mix of instruction and data items. The Arm AXI specification for both AXI 3 and AXI 4 recommends that a manager sets bit 2 to zero to indicate a data access, unless the access is specifically known to be an instruction access.

Cache support

Modern SoC systems often contain caches that are placed in several points of the system. For example, the level 2 cache might be external to the processor, or the level 3 caches might be in front of the memory controller.

To support systems that use different caching policies, the AWCACHE and ARCACHE signals indicate how transactions are required to progress through a system.

The following diagram shows the AxCACHE bit allocations:

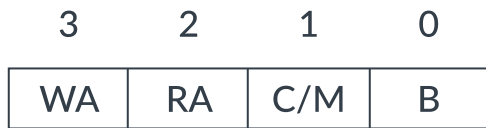
Figure 5-2: Cache support

The AxCACHE bit allocations specify the following attributes:

- AxCACHE [0] (B) is the bufferable bit. When this bit is set to 1, the interconnect or any component can delay the transaction reaching its final destination for any number of cycles. The bufferable bit indicates whether the response can come from an intermediate point, or whether the response must come from the destination subordinate.
- AxCACHE [1] is the cacheable bit in AXI3, or the modifiable bit in AXI4. This bit indicates that the attributes of a transaction at the final destination do not have to match the attributes of the original transaction. For writes, setting the modifiable bit means that several different writes can be merged, or a single write can be broken into multiple transactions. For reads, setting the modifiable bit means that the contents of a location can be prefetched, or the values from a single fetch can be used for multiple read transactions.
- AxCACHE [2] is the RA bit. The RA bit indicates that on a read, the allocation of the transaction is recommended, but not mandatory. If either AxCACHE [2] or AxCACHE [3] is asserted, then the transaction must be looked up in a cache as it could have been allocated in this cache by another manager.
- AxCACHE [3] is the WA bit. The WA bit indicates that on a write, the allocation of the transaction is recommended, but not mandatory. If either AxCACHE [2] or AxCACHE [3] is asserted, then the transaction must be looked up in a cache as it could have been allocated in this cache by another manager.



If AxCACHE [1], the cacheable bit, is not asserted, then AxCACHE [2] and AxCACHE [3] cannot be asserted.

The reason for including read and write allocation on both read and write address buses is that it allows a system-level cache to optimize its performance.

For example, consider a cache that sees a read access defined as “write-allocate, but not read-allocate”. In this case, the cache knows that the address might be stored in the cache because it could have been allocated on a previous write, and therefore it must do a cache lookup.

However, now consider that the cache sees a read access that is defined as “no write-allocate and no read-allocate”. In this case, the cache knows that the address has not been allocated in the cache. The cache can avoid the lookup and immediately pass the transaction through to the other side. The cache can only do this if it knows both the read and write allocate for every transaction.

It is not a requirement that caches operate in this way, but the AXI protocol is defined with RA and WA for both reads and writes to allow this mode of operation if you or your cache designer want to implement it.

Response signaling

AXI provides response signaling for both read and write transactions.

For read transactions, the response information from the subordinate is signaled on the read data channel using RRESP.

For write transactions, the response information is signaled on the write response channel using BRESP.

RRESP and BRESP are both composed of two bits, and the encoding of these signals can transfer four responses, as shown in the following table:

Response code	Description
00 - OKAY	<p>Normal access success or exclusive access failure.</p> <p>OKAY is the response that is used for most transactions. OKAY indicates that a normal access has been successful.</p> <p>This response can also indicate that an exclusive access has failed. An exclusive access is when more than one manager can access a subordinate at once, but the se managers cannot access the same memory range.</p>
01 - EXOKAY	<p>Exclusive access okay.</p> <p>EXOKAY indicates that either the read or write portion of an exclusive access has been successful.</p>
10 - SLVERR	<p>Subordinate error.</p> <p>SLVERR is used when the access has reached the subordinate successfully, but the subordinate wants to return an error condition to the originating manager.</p> <p>This indicates an unsuccessful transaction. For example, when there is an unsupported transfer size attempted, or a write access attempted to read-only location.</p>
11 - DECERR	<p>Decode error.</p> <p>DECERR is often generated by an interconnect component to indicate that there is no subordinate at the transaction address.</p>

Write data strobes The write data strobe signal is used by a manager to tell a subordinate which bytes of the data bus are required. Write data strobes are useful for cache accesses for efficient movement of sparse data arrays. In addition to using write data strobes, you can optimize data transfers using unaligned start addresses.

The write channel has one strobe bit per byte on the data bus. These bits make the WSTRB signal.

A manager must ensure that the write strobes are set to 1 only for byte lanes that contain valid data.

For example, consider a 64-bit write data bus. The WSTRB signal has 8 bits, one for each byte. The following diagram shows how example WSTRB values specify which byte lanes are valid:

Figure 5-3: Write data strobes

For 64 bit WDATA bus

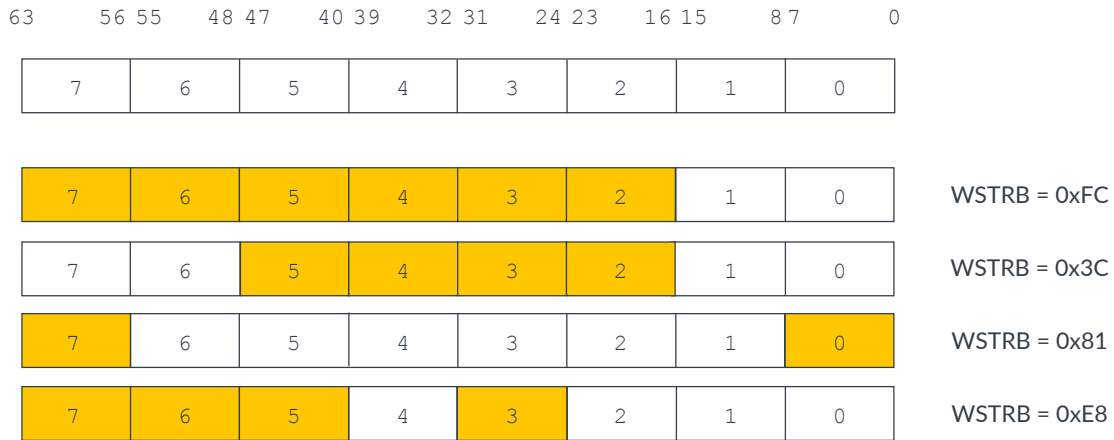

Looking at the first example, we suppose that the valid data are only in the top six significant bytes of the data bus, from byte 7 to byte 2. This means that the manager has to control the WSTRB signal with the hexadecimal value 0xFC.

Similarly, the remaining examples specify valid data bus byte lanes as follows:

- Valid data only in bytes 2, 3, 4, and 5 of the data bus requires a WSTRB signal value of 0x3C.
- Valid data only in bytes 0 and 7 of the data bus requires a WSTRB signal value of 0x81.
- Valid data only in bytes 3, 5, 6, and 7 of the data bus requires a WSTRB signal value of 0xE8.

Byte lane strobes offer efficient movement of sparse data arrays. Using this method, write transactions can be early terminated by setting the remaining transfer byte lane strobes to 0, although the remaining transfers must still be completed. The WSTRB signal can also change between transfers in a transaction.

There is no equivalent signal for the read channel. This is because the manager indicates the transfer required and can mask out any unwanted bytes received from the subordinate.

Atomic accesses with the lock signal

The AxLOCK signal is used to indicate when atomic accesses are being performed. See Atomic accesses for more information and an explanation of the concept and operation of exclusive access transfers.

The AXI protocol provides two mechanisms to support atomicity:

- **Locked accesses** A locked transfer locks the channel, which remains locked until an unlocked transfer is generated. Locked accesses are similar to the mechanism supported with the AHB protocol. When a manager uses the AxLOCK signals for a transaction to show that it is a locked transaction, then the interconnect must ensure that only that manager can access the targeted subordinate region, until an unlocked transaction from the same manager completes.

An arbiter within the interconnect must enforce this restriction. Because locked accesses require the interconnect to prevent any other transactions occurring while the locked sequence is in progress, they can have an important impact on the interconnect performance. Locked transactions should only be used for legacy devices. Only AXI3 supports locked accesses. AXI4 does not support locked accesses.

- Exclusive accesses Exclusive accesses are more efficient than locked transactions, and they allow multiple managers to access a subordinate at the same time. The exclusive access mechanism enables the implementation of semaphore-type operations, without requiring the bus to remain locked to a particular manager during the operation. Because locked accesses are not as efficient as exclusive accesses, and most components do not require locked transactions, they have been removed from the AXI4 protocol.

In AXI3, the AxLOCK signal consists of two bits with the following values:

- 0b00 - Normal
- 0b01 - Exclusive
- 0b10 - Locked
- 0b11 - Reserved

In AXI4, the AxLOCK signal consists of one bit, with the following values:

- 0b0 - Normal
- 0b1 - Exclusive

Quality of service

The AXI4 protocol introduces extra signals to support the quality of service (QoS).

Quality of service allows you to prioritize transactions allowing you to improve system performance, by ensuring that more important transactions are dealt with higher priority.

There are two quality of service signals:

- AWQOS is sent on the Write Address channel for each write transaction.
- ARQOS is sent on the Read Address channel for each read transaction.

Both signals are 4 bits wide, where the value 0x0 indicates the lowest priority, and the value 0xF indicates the highest priority.

The default system-level implementation of quality of service is that any component with a choice of more than one transaction processes the transaction with the higher QoS value first.

The following diagram shows an example system with a Direct Memory Controller (DMC), specifically the DMC-400. This controller manages transactions to DRAM:

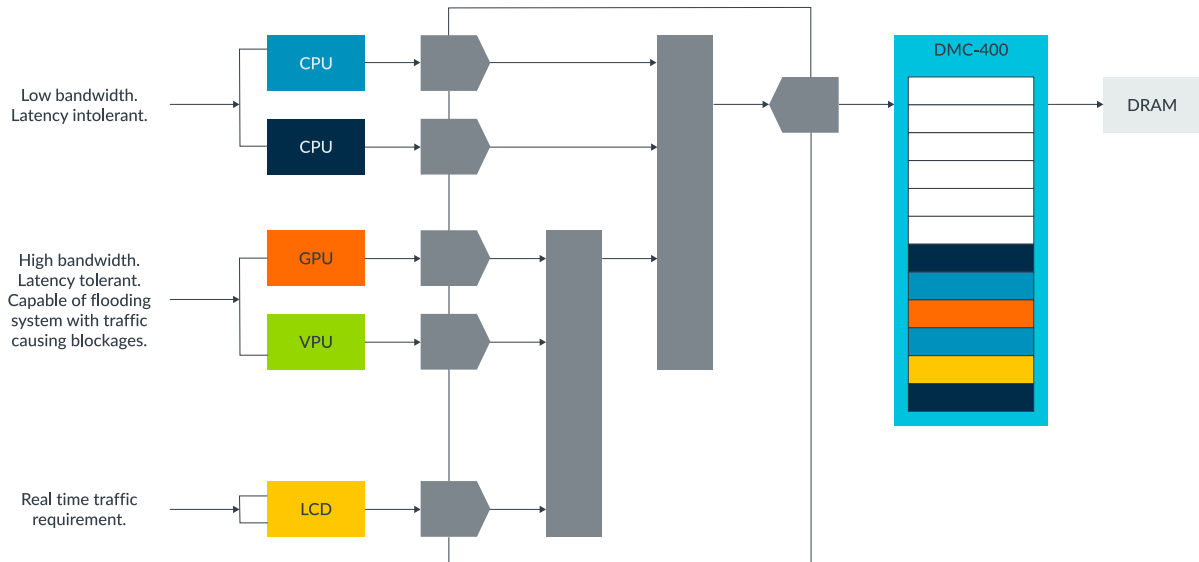
Figure 5-4: QoS

In practice, some elements, like the CPU, require memory accesses that are far more important than those of other components, like the GPU or the VPU.

When appropriate QoS values are assigned to transactions, the interconnect can arbitrate higher priority transaction ahead of lower priority transactions and the DMC reorders transactions to ensure that the correct priority is given.

Region signaling

Region signaling is an optional feature in AXI4.

When you use region identifiers, it means that a single physical interface on a subordinate can provide multiple logical interfaces. Each logical interface can have a different location in the system address map.

When the region identifier is used, the subordinate does not have to support the address decode between the different logical interfaces.

Region signaling uses two 4-bit region identifiers, AWREGION and ARREGION. These region identifiers can uniquely identify up to 16 different regions.

User signals

The AXI4 interface signal set has the option to include a set of user-defined signals, called the User signals.

User signals can be used on each channel to transfer extra custom control information between manager and subordinate components. These signals are optional and do not have to be supported on all channels. If they are used, then the width of the User signals is defined by the implementation and can be different on each channel.



Because the AXI protocol does not define the functions of these User signals, interoperability issues can arise if two components use the same User signals in a way that is incompatible.

AXI channel dependencies

The AXI protocol defines dependencies between the different channels.

Three of the main dependencies are as follows:

- WLAST transfer must complete before BVALID is asserted.
 - The manager must send all the write data before a write response can be seen by the manager. This dependency does not exist in AXI3 but is introduced for AXI4:
 - In AXI3, the address does not have to be seen before a write response is sent.
 - In AXI4, all of the data and the address must have been transferred before the manager can see a write response.
- RVALID cannot be asserted until ARADDR has been transferred.
 - The subordinate cannot transfer any read data without it seeing the address first. This is because the subordinate cannot send data back to the manager if it does not know the address that the data will be read from.
- WVALID can assert before AWVALID.
 - A manager could use the Write Data channel to send data to the subordinate, before communicating the address where the subordinate should write these data.

6. Atomic accesses

An atomic access is a term for a series of accesses to a memory region. Atomic accesses are used by managers when they would like to perform a sequence of accesses to a particular memory region, while being sure that the original data in the region are not corrupted by writes from other managers. This sequence is commonly a read, modify, and write sequence.

There are two types of atomic accesses:

- **Locked** While a manager is performing a transaction sequence with locked accesses, accesses from any other managers to the same subordinate are rejected.
- **Exclusive** When a manager successfully performs a transaction sequence with exclusive accesses, other managers can access the subordinate but not the memory region that is being accessed.

Locked accesses

Locked transactions should only be used for legacy devices. AXI4 does not support locked transactions, but AXI3 implementations must support locked transactions.

Before a manager can start a locked sequence of transactions, it must ensure that it has no other transactions waiting to complete.

A transaction with the AxLOCK signal set indicates a locked transaction. A locked sequence of transactions forces the interconnect to reject access to the subordinate from any other managers.

The locked sequence must always complete with a final transaction that does not have the AxLOCK signal set. This final transaction is still included in the locked sequence, but effectively removes the lock to allow other managers access to the subordinate.

Because locked accesses require the interconnect to prevent any other transactions occurring while the locked sequence is in progress, they have an important impact on the interconnect performance.

The following diagram shows the AXI locked access operation with an example using two managers, M0 and M1:

Figure 6-1: AXI locked access operation

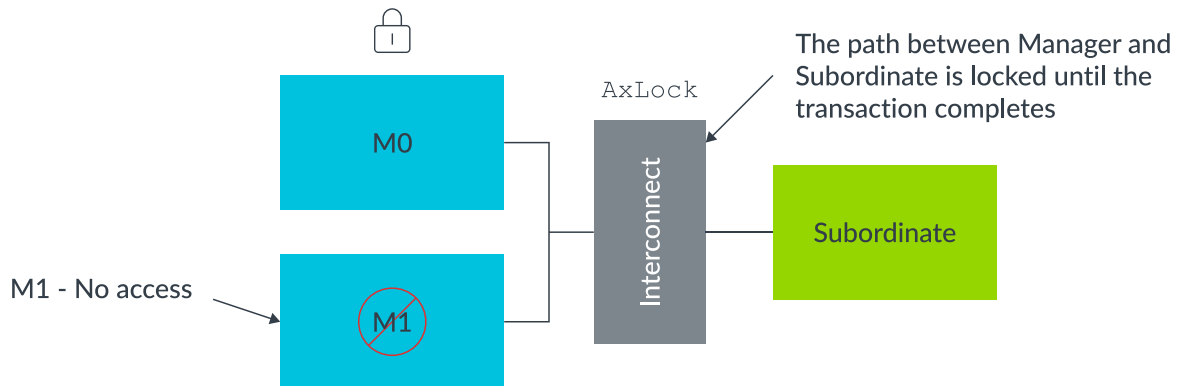

Before a manager can start a locked sequence of transactions, the manager must ensure that it has no other transactions that are waiting to complete.

When M0 uses a lock signal for a transaction to indicate that it is a locked transaction, then the interconnect uses an arbiter to ensure that only M0 can access the targeted subordinate. The interconnect blocks any accesses from M1 until an unlocked transaction from M0 completes.

The following diagram shows how locked access works with a sequence of transactions:

Figure 6-2: Locked access with a sequence of transactions

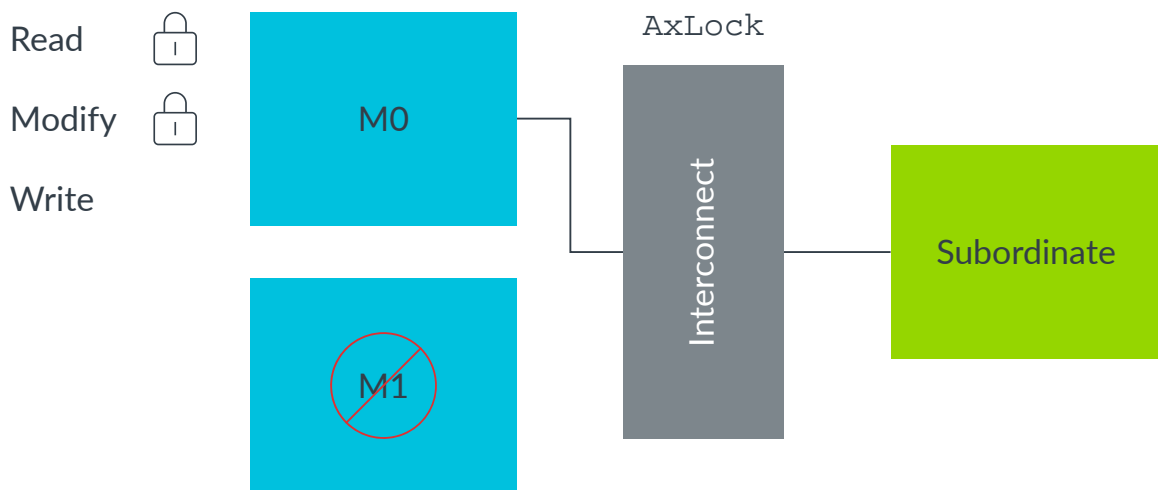

The steps in this example are as follows:

1. Manager M0 initiates a sequence of READ, MODIFY, and WRITE. The first transaction, READ, has the LOCK signal asserted, indicating that it starts a locked transaction.

2. The interconnect locks out any other transactions. From this point, manager M1 has no access to the subordinate.
3. The final transaction in the sequence, WRITE, does not have the LOCK signal asserted. This transaction indicates the end of the locked sequence. The interconnect removes the lock, and other managers can now access the subordinate.

Figure 6-3: Other managers can now access the subordinate

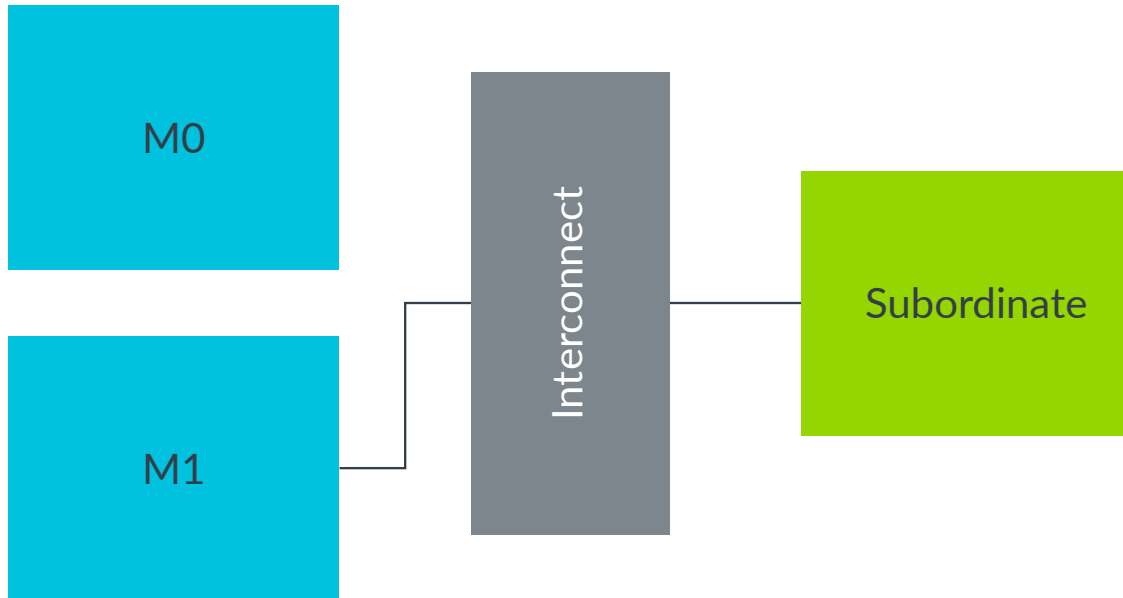

Exclusive accesses

With AXI 4, exclusive accesses perform atomic operations more efficiently than locked accesses. This is because exclusive accesses use the interconnect bandwidth more effectively.

In an exclusive access sequence, other managers can access the subordinate at the same time, but only one manager will be granted access to the same memory range.

The mechanism that is used for exclusive accesses can provide semaphore-type operations without requiring the bus to remain dedicated to a particular manager during the operation. This means that the bus access latency and the maximum achievable bandwidth are not affected.

Exclusive accesses can be composed of more than one data transfer, but all the transactions must have identical address channel attributes.

A hardware exclusive access monitor is required by the subordinate to record the transaction information for the exclusive sequence so that it knows the memory range that is being accessed and the identity of the manager performing the access.

If no other manager accesses the monitored range until the exclusive sequence is completed, the access is atomic.

The subordinate is open to accesses from other managers, resulting in overall increased fairness in bandwidth utilization for the system.

Exclusive access hardware monitor operation

The basic mechanism of an exclusive access is governed by an exclusive access monitor that you must implement.

The following diagram shows an example where the manager M0 performs an exclusive read from an address:

Figure 6-4: The manager M0 performs an exclusive read from an address

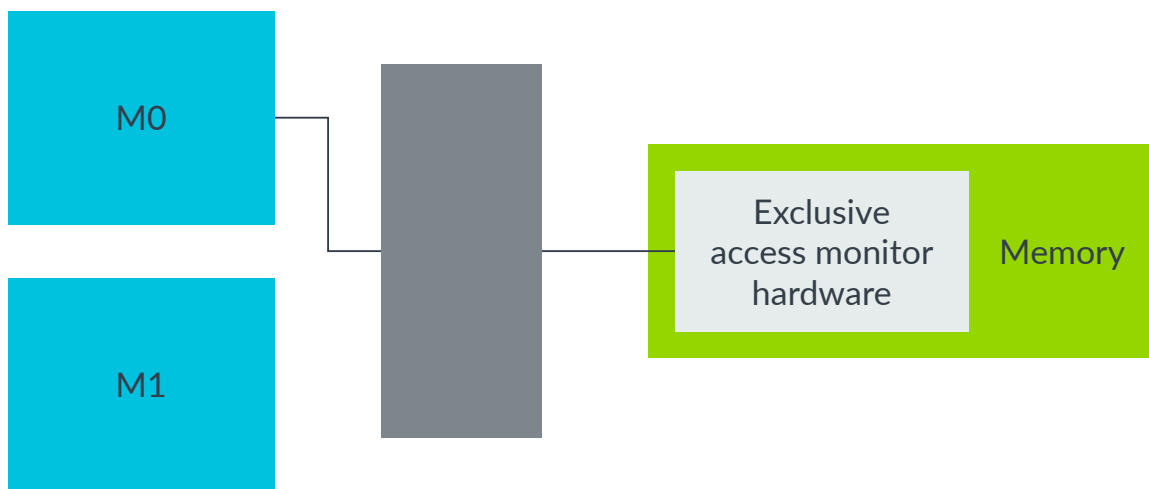

The response from the exclusive access monitor hardware is one of the following:

- EXOKAY: The value is read, and the ID of the transaction is stored in the exclusive access monitor hardware.
- OKAY: The value is read, but there is no support for exclusive access, and the manager should treat this response as an error for the exclusive operation.

At some later time, if EXOKAY was received during the exclusive read, M0 attempts to complete the exclusive sequence by performing an exclusive write to the same address. The exclusive write uses the same transaction ID as the exclusive read.

The response from the exclusive access monitor hardware is one of the following:

- EXOKAY: No other manager has written to that location since the exclusive read access, so the write is successful. In this case, the exclusive write updates memory.

- OKAY: Another manager, for example M1, has written to the location since the exclusive read access, so the write fails. In this case, the memory location is not updated.

Some subordinates require extra logic to support exclusive access. The exclusive access monitoring hardware monitors only one address for each transaction ID. It should be implemented so that it can monitor every possible exclusive ID that can be seen.

Exclusive transaction pairs: both pass

This section describes an example of two successful exclusive access sequences that both pass.

The following diagram shows a system containing a manager, with its AXI manager interface, and a subordinate:

Figure 6-5: Two successful exclusive access sequences. Both pass

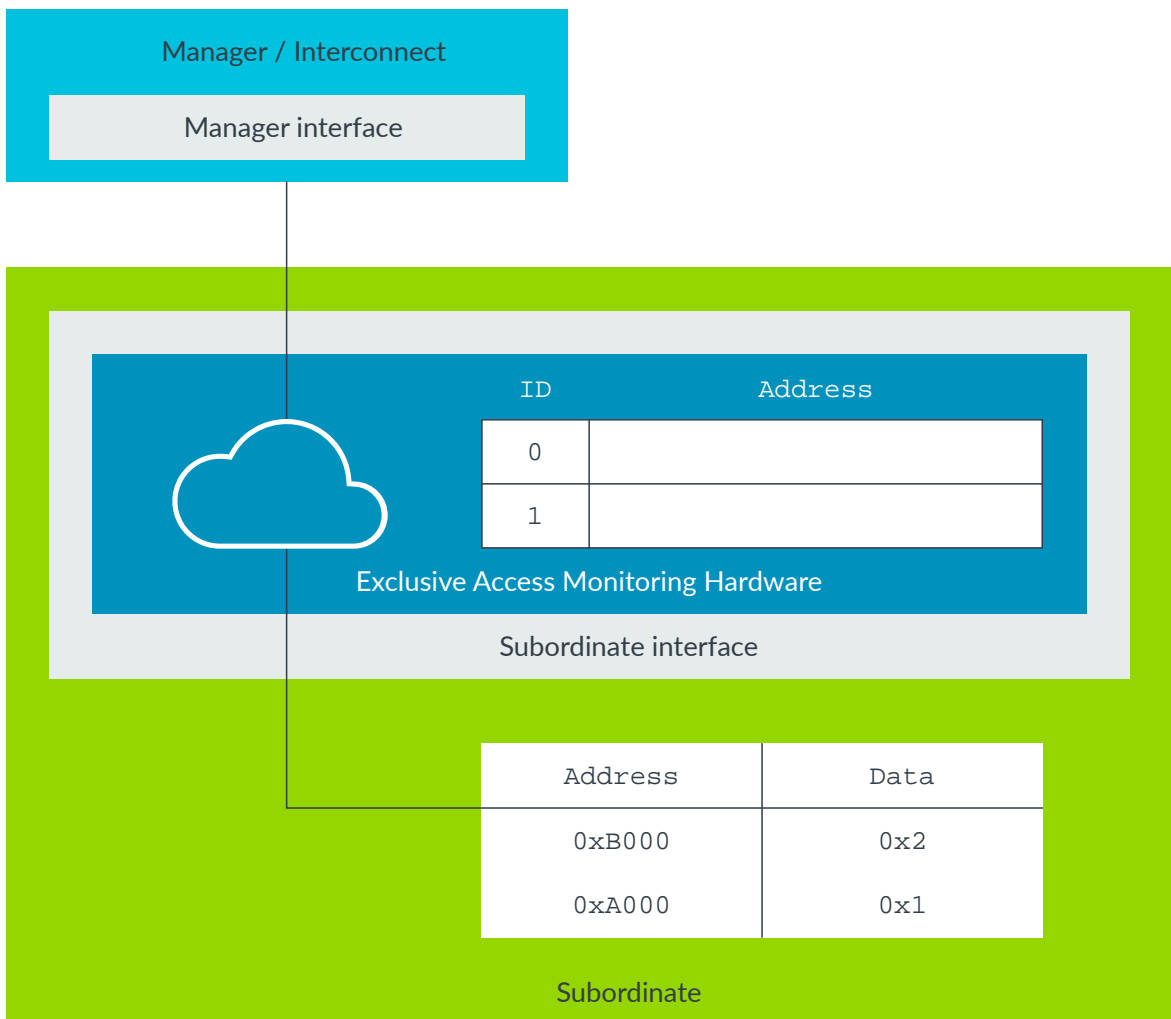

The subordinate interface includes exclusive access monitoring hardware that can save the ID and the address accessed for each transaction.

The following table describes the different transactions in the example sequence. All transactions in the table are exclusive accesses:

Transaction number	Read or write	Transaction ID	Address	Data	xRESP
1	R	0	0xA000	0x1	EXOKAY
2	R	1	0xB000	0x2	EXOKAY
3	W	0	0xA000	0x3	EXOKAY
4	W	1	0xB000	0x4	EXOKAY

The transaction sequence shown in the previous table proceeds as follows:

1. The first transaction is the manager, which performs a read exclusive transaction with ID 0 from address 0xA000. The exclusive access monitoring hardware saves the ID and address of this transaction in its table, and the subordinate responds with the read data, 0x1. Because exclusive accesses are correctly supported for this subordinate, the exclusive access monitoring hardware responds with an EXOKAY response.
2. Next, the manager performs a new read exclusive transaction with ID 1 from address 0xB000. Again, the exclusive access monitoring hardware saves the details of this new transaction in the table, and the subordinate responds with the read data, 0x2. Because exclusive accesses are correctly supported for this subordinate, the exclusive access monitoring hardware again responds with an EXOKAY response. At this moment in our example there are two separate exclusive sequences ongoing.
3. After the manager has completed its operation, it performs a write exclusive transaction with ID 0 to address 0xA000. The exclusive access monitoring hardware checks the detail of this transaction in the table and, because of the existing record with ID 0 and address 0xA000, responds to the manager with an EXOKAY response. This means that no other manager has accessed this memory location, and the subordinate updates it with the new value it receives, which in this example is 0x3. The exclusive access monitoring hardware removes the ID and address for this transaction from its table, because the exclusive access sequence for that address location is now complete.
4. Finally, the manager performs a new write exclusive transaction with ID 1 to address 0xB000. The exclusive access monitoring hardware checks the detail of this transaction in its table. Seeing an existing record with ID 1 and address 0xB000, it again responds to the manager with an EXOKAY response. This means that no other manager has accessed this memory location, and the subordinate updates it with the new value received, which in our example is 0x4. Again, the exclusive access monitoring hardware removes the ID and address for this transaction from its table, because the exclusive access sequence for that address location is now complete.

Exclusive transaction pairs: one pass, one fail

This section describes an example of two exclusive access sequences, where the first one succeeds and the second one fails.

The following diagram shows a system containing a manager, with its AXI manager interface, and a subordinate:

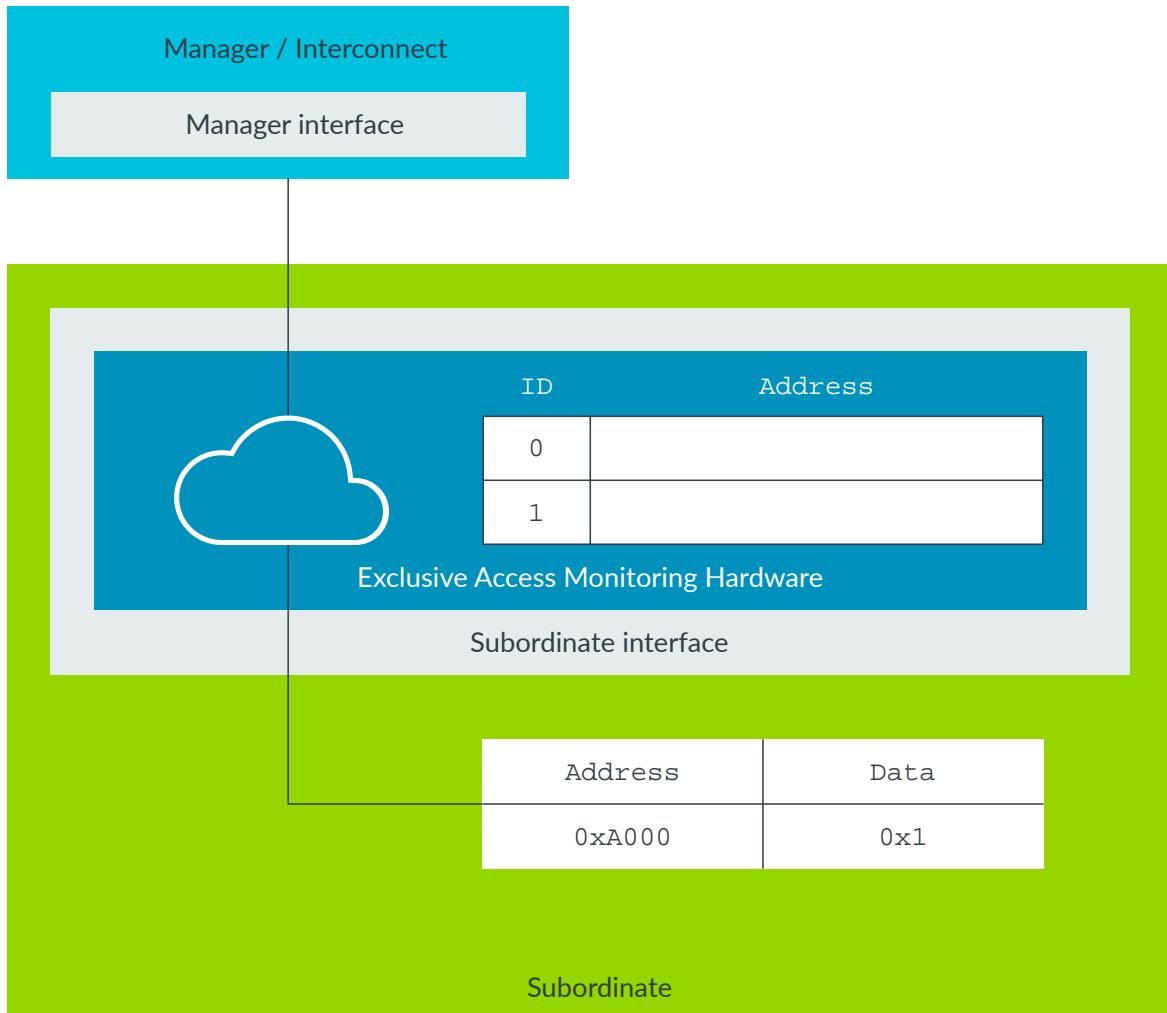
Figure 6-6: Two exclusive access sequences, where the first one succeeds and the second one fails

The subordinate interface includes exclusive access monitoring hardware that can save the ID and the address accessed for each transaction.

The following table describes the different transactions in the example sequence. All transactions in the table are exclusive accesses:

Transaction number	Read or write	Transaction ID	Address	Data	xRESP
1	R	0	0xA000	0x1	EXOKAY
2	R	1	0xA000	0x1	EXOKAY
3	W	0	0xA000	0x3	EXOKAY
4	W	1	0xA000	0x4	OKAY

The transaction sequence shown in the previous table proceeds as follows:

1. The first transaction is the manager performing a read exclusive transaction with ID 0 from address `0xA000`. The exclusive access monitoring hardware saves the ID and address of this transaction in its table, and the subordinate responds with the read data, `0x1`. Because exclusive accesses are correctly supported for this subordinate, the exclusive access monitoring hardware responds with an EXOKAY response.
2. Later, the manager performs a new read exclusive transaction with ID 1 from the same address as the first transaction, `0xA000`. The exclusive access monitoring hardware saves the detail of this new transaction in the table, and the subordinate responds with the read data, `0x1`. Again, because exclusive accesses are correctly supported for this subordinate, the exclusive access monitoring hardware responds with an EXOKAY response. At this moment in our example, we have two different ongoing exclusive sequences to the same memory location.
3. After the manager has completed its operation, it performs an exclusive write transaction with ID 0 to address `0xA000`. The exclusive access monitoring hardware checks the detail of this transaction in its table and, seeing a record with ID 0 and address `0xA000`, responds to the manager with an EXOKAY response. This means that no other manager has updated this memory location, and the subordinate can update it with the new value received, which in our example is `0x3`. Because the content of the address location `0xA000` has been modified, the exclusive access monitoring hardware removes from its table all the entries that match that location address.
4. Finally, the manager performs a new write exclusive transaction with ID 1 again to address `0xA000`. The exclusive access monitoring hardware checks the detail of this transaction in its table. Not finding any records with the address `0xA000`, it responds with an OKAY response. The OKAY response means that a previous write operation has been performed on this memory location which updated the data. In this case, the subordinate cannot update the memory location with the new value, `0x4`. This situation is an exclusive access failure. In this case, the manager must restart the full exclusive access sequence beginning with the exclusive read and then the exclusive write again.

This example demonstrates how exclusive accesses implement non-blocking behavior. It is this behavior that provides greater system throughput when compared with LOCK accesses.

7. Transfer behavior and transaction ordering

This section of the guide analyzes some example sequences of read and write transactions, to help you understand the relationships between the different AXI channels. This section also explains some of the rules that govern transactions and how transfer IDs can support out-of-order transactions.

We will also look at:

- Unaligned transfers, and how they help optimize bandwidth utilization
- The differences between big-endian and little-endian encoding, with some simple examples
- The main parameters that are related to the AXI interfaces. These parameters are useful when implementing an interconnect

Examples of simple transactions

Examples of simple transactions help to explain the relationships between the different AXI channels.

The following diagram shows a time representation of several valid transactions on the five channels of an AXI3 or AXI4 interface:

Figure 7-1: A time representation of several valid transactions

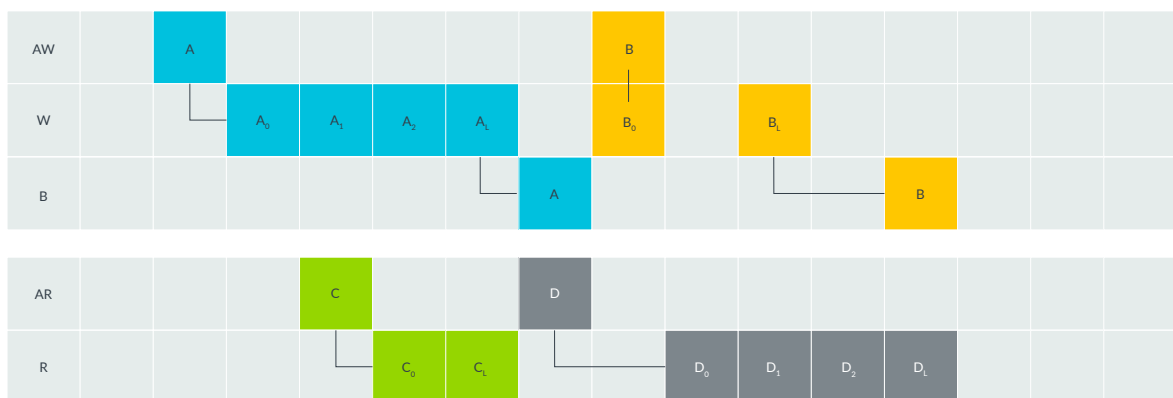

The different transactions in this example are as follows:

1. Transaction A, which is a write transaction that contains four transfers. The manager first puts the address A on the AW channel, then soon puts the sequence of four data transfers on the W channel, ending with AL where L stands for last. Once all four data transfers complete, the subordinate responds on the channel.

2. While transaction A was occurring, the manager also used the read channels to perform a read transaction, C, which contains two transfers. Because this is a read transaction, there is no response from the subordinate on a different channel when the transaction completes. Instead, the response from the subordinate is included in the R channel at the same time as the data.
3. Once transaction C completes, the manager uses the Read Address channel AR to send a new read address, D, to the subordinate. In this case, the response from the subordinate is not immediate. This is indicated by the empty time slot between D and D₀. Delays like this can happen. The subordinate is not obliged to answer immediately. For example, the subordinate could be busy performing another operation, or it could take time to retrieve the data. Eventually, the subordinate responds with four sequential transfers, D₀ through D₃, on the R channel.
4. Finally, while the read transaction D is ongoing, the manager uses the Write Address channel, AW, to send a new address, B, to the subordinate for a write operation. The manager puts the data B₀ on the W channel at the same time as it puts the corresponding address B on the AW channel. There is a delay in this example between data transfers B₀ and B₁, and another delay before the response B. The transaction completes only when the subordinate sends the response to the manager. All of these examples are valid transactions.

The following diagram shows the same sequence of read and write transactions in a different, but still valid, timeline:

Figure 7-2: Same sequence of read and write transactions in a different timeline

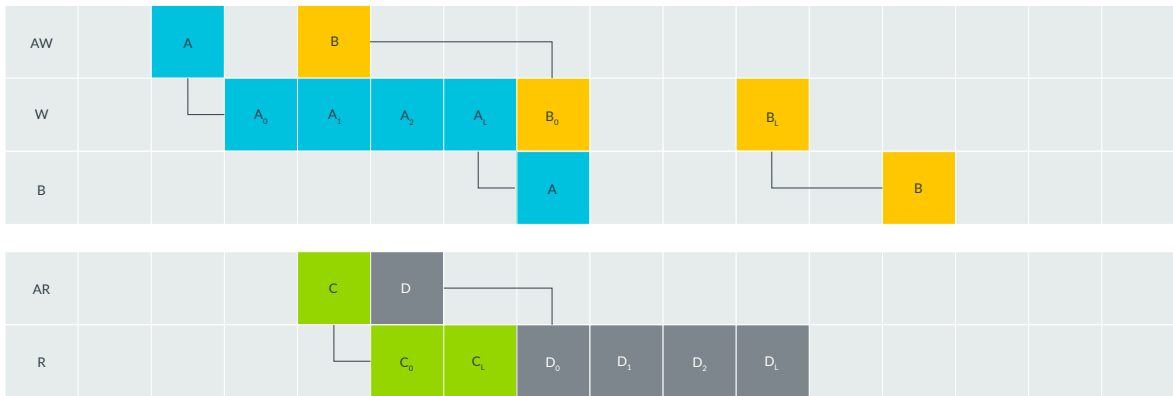

In this example, the manager starts transaction B before it has finished transaction A.

The manager uses the Write Address channel, AW, to start a new transaction by transferring a new address B to the subordinate before it has finished transferring the data for transaction A on the W channel.

The data for transaction B is transferred to the subordinate when all the data for transaction A have completed. The manager does not wait for a response on the B channel for transaction A before it starts to transfer the data for transaction B.

At the same time, the manager uses the Read Address channel to transfer in sequence the read addresses C and D for the subordinate. The subordinate responds in sequence to the two read requests.

This example shows a different valid combination of read and write transactions happening on the different channels. This shows the flexibility of the AXI protocol and the possibility to optimize the interconnect performance.

Transfer IDs

The AXI protocol defines an ID signals bus for each channel. Marking each transaction with an ID gives the possibility to complete transactions out of order. This means that transactions to faster memory regions can complete without waiting for earlier transactions to slower memory regions. The use of transfer IDs enables the implementation of a high-performance interconnect, maximizing data throughput and system efficiency. This feature can also improve system performance because it reduces the effect of transaction latency.

The ID signal buses are as follows:

- AWID
- WID
- BID
- ARID
- RID

The AXI protocol supports out-of-order transactions by enabling each interface to act as multiple ordered interfaces. According to the AXI protocol specifications, all transactions with a given ID must be ordered. However, there is no restriction on the ordering of transactions with different IDs.

When working with transfer IDs, follow these rules:

- All transfers must have an ID.
- All transfers in a transaction must have the same ID.
- Managers can support multiple IDs for multiple threads.
- Subordinates generally need a configurable ID width.

You should also remember these two important AXI parameters for ID signals:

- The write ID width, which is the number of bits used for the AWID, WID and BID buses
- The read ID width, which is the number of bits used for the ARID and RID buses

Write transaction ordering rules

There are three AXI ordering rules for write transactions.

The rules are as follows:

- Write data on the W channel must follow the same order as the address transfers on the AW channel. The following diagram illustrates this rule:

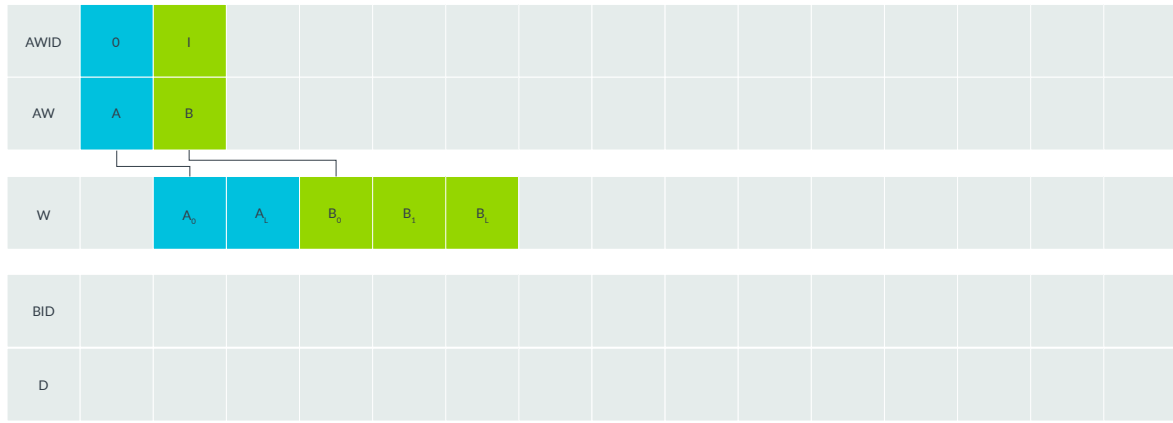
Figure 7-3: Write data on the W channel must follow the same order as the address transfers on the AW channel

In this example, the manager issues address A then B, so data must start with A0 before B0.



The interleaving of write data with different IDs on the W channel was permitted in AXI3, but is deprecated in AXI4 and later.

- Transactions with different IDs can complete in any order. The following diagram illustrates this rule:

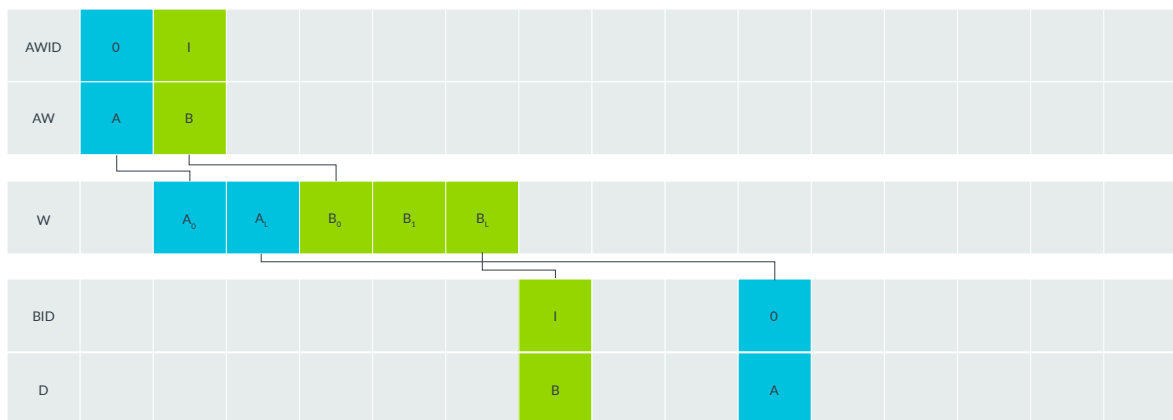
Figure 7-4: Transactions with different IDs can complete in any order

In this example, transaction B completes before transaction A, even though transaction A started first.

- A manager can have multiple outstanding transactions with the same ID, but they must be performed in order and complete in order. The following diagram illustrates this rule:

Figure 7-5: A manager can have multiple outstanding transactions with the same ID, but they must be performed in order and complete in order

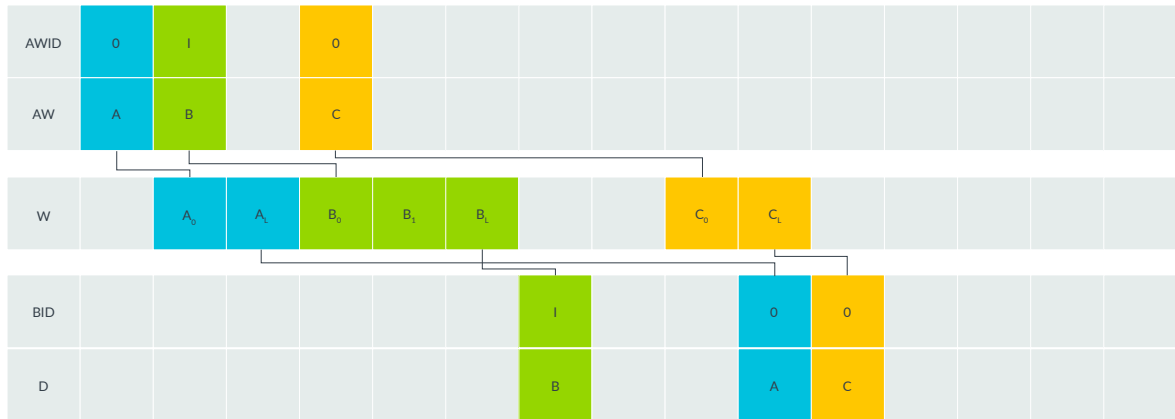

In this example, transaction B has a different ID from the other transactions, so it can complete at any point. However, transactions A and C have the same ID, so they must complete in the same order as they were issued: A first, then C.

Read transaction ordering rules

There are three ordering rules for read transactions.

The rules are as follows:

- Read data for different IDs on the R channel has no ordering restrictions. This means that the subordinate can send it in any order. The following diagram shows an example where transaction B is serviced before A, even though the address for transaction A is received first:

Figure 7-6: Transaction B is serviced before A, even though the address for transaction A is received first

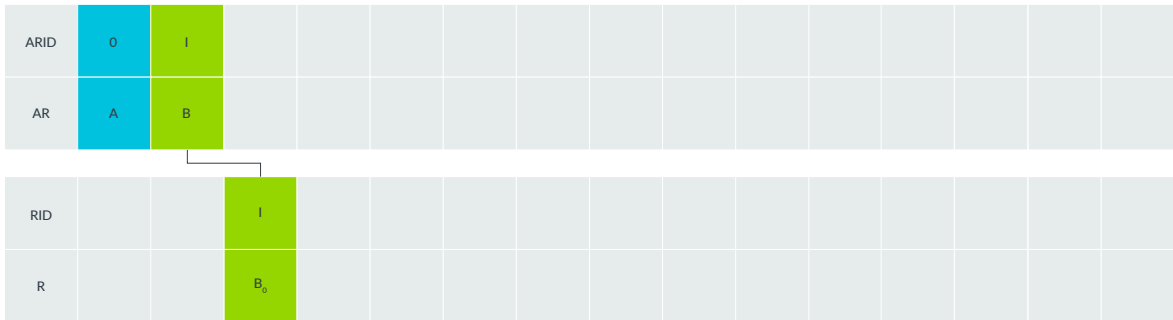

- The read data for the different IDs on the R channel can be interleaved, with the RID value differentiating which transaction the data relates to. The following diagram shows an example where R data for transactions A and B are interleaved:

Figure 7-7: R data for transactions A and B are interleaved

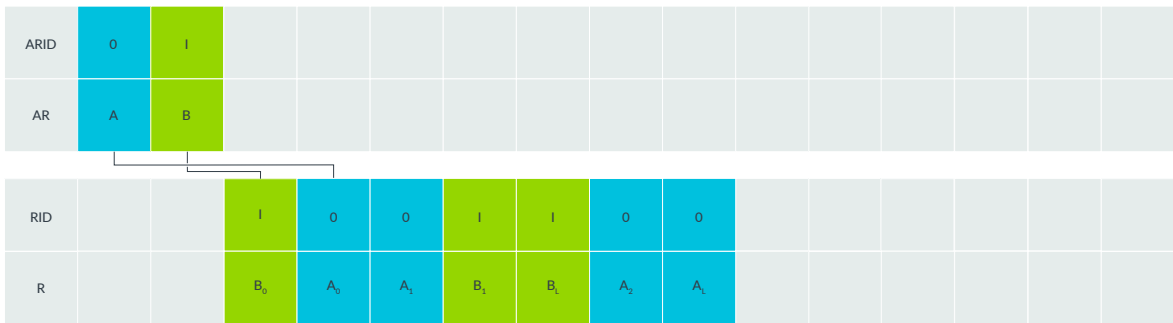

- For transactions with the same ID, read data on the R channel must be returned in the order that they were requested. The following diagram shows an example where transactions A and C have the same RID value of 0:

Figure 7-8: Transactions A and C have the same RID value of 0



Because transaction A was requested before transaction C, the subordinate must return all four R data values for A before the data values for C.

Read and write channel ordering

Read and write channels have no ordering rules in relation to each other. This means that they can complete in any order. So, if a manager requires ordering for a specific sequence of reads and writes, the manager must ensure that the transaction order is respected by explicitly waiting for transactions to complete before issuing new ones.

The following diagram shows an example where the manager requires a specific ordering for a write-read-write transaction sequence from an address:

Figure 7-9: The manager requires a specific ordering for a write-read-write transaction sequence from an address

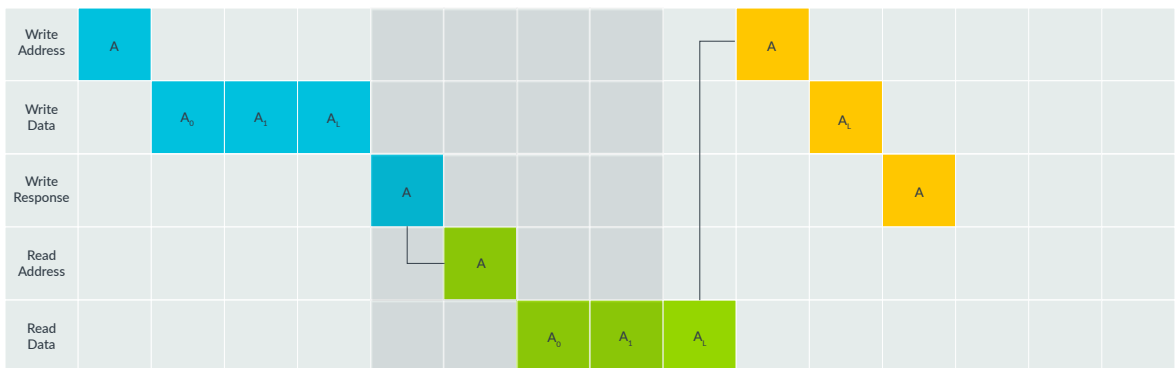

The sequence of operations is as follows:

1. The manager starts the first write transaction.
2. The manager ensures that the subordinate has completed the write transaction by waiting for the signal on the Write Response channel.
3. The manager starts the read transaction.
4. The manager waits for the final response on the Read Data channel.
5. The manager starts the second transaction.

Unaligned transfer start address

The AXI protocol supports transactions with an unaligned start address that only affects the first transfer in a transaction. After the first transfer in a transaction, all other transfers are aligned.



The AXI protocol also supports unaligned transfers using the strobe signals. See Write data strobes for more information.

An unaligned transfer is where the AxADDR values do not have to be aligned to the width of the transaction. For example, a 32-bit data packet that starts at a byte address of 0x1002 is not aligned to the natural 32-bit address boundary because 0x1002 is not exactly divisible by 0x20.

The following example shows a 5-beat 32-bit transfer starting at an unaligned address of 0x01:

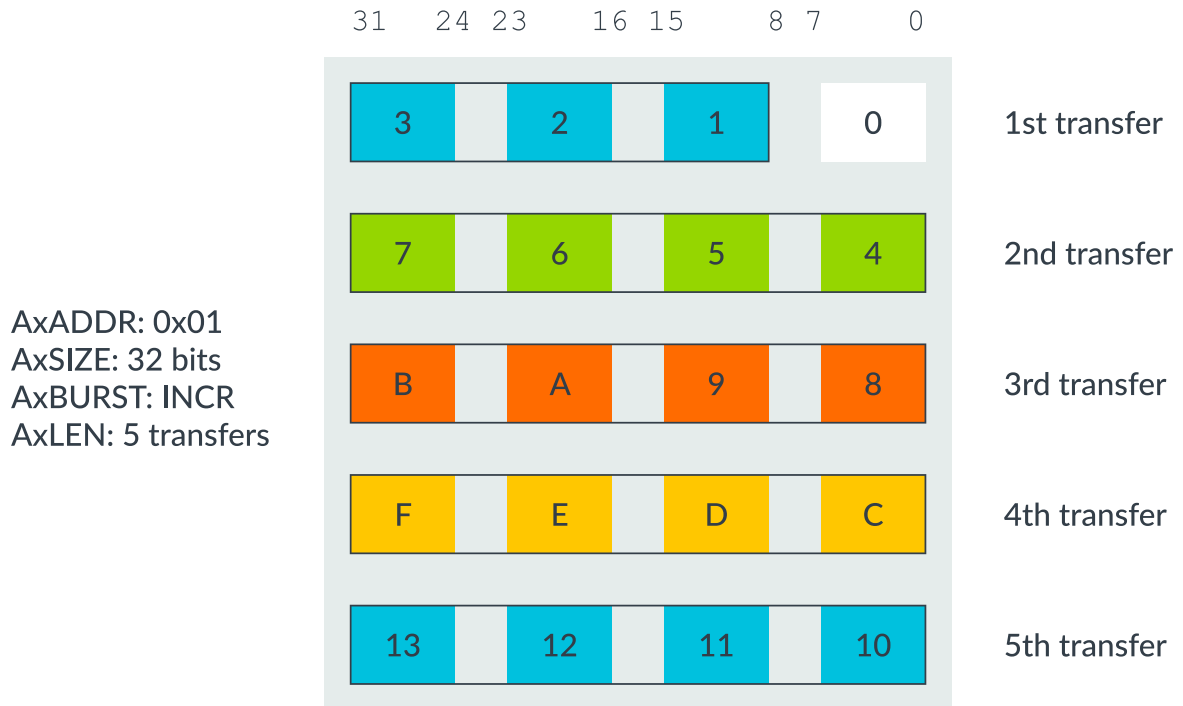
Figure 7-10: A 5-beat 32-bit transfer starting at an unaligned address of

If the transaction were aligned to a start address of 0x00, the result would be a five-beat burst with a width of four bytes giving a maximum data transfer of 20 bytes. However, we have an unaligned start address of 0x1. This reduces the total data volume of the transfer, but it does not mean a final unaligned transfer to complete the burst and make up the volume. In this example, the first transfer starts at address 0x01 and contains three bytes. All the following transfers in the burst are aligned with the bus width and are composed of four bytes each.

The following example shows a five-beat 16-bit-sized transaction starting at address 0x03:

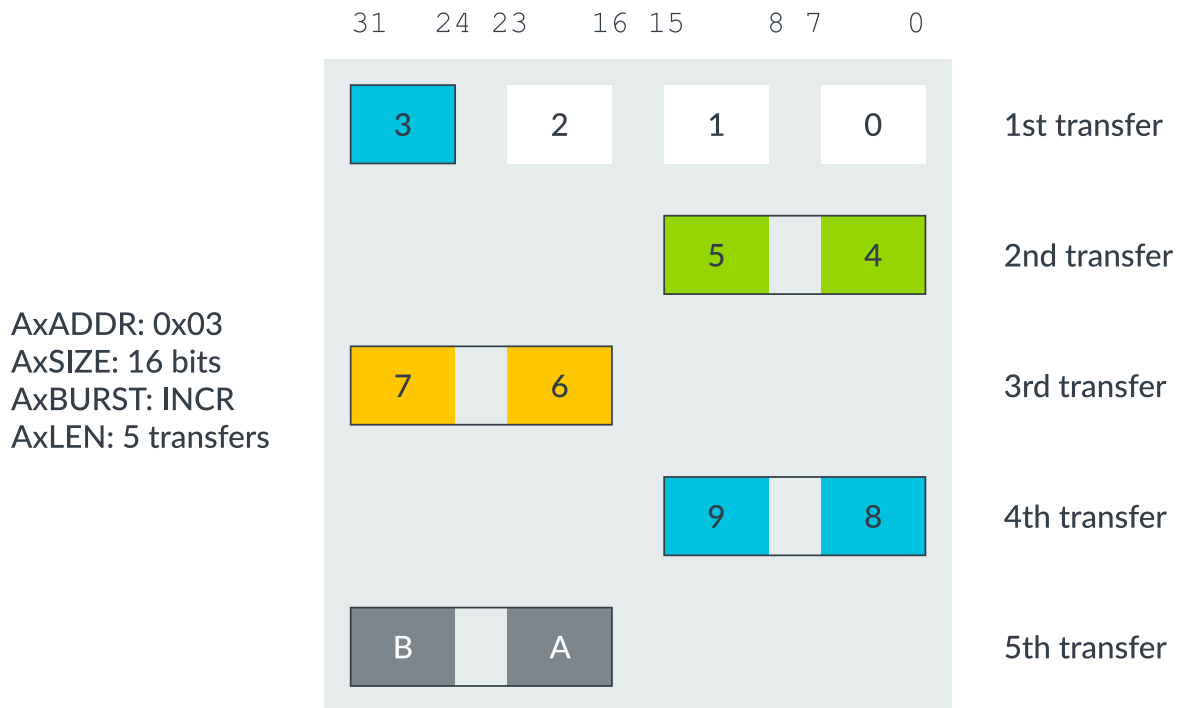
Figure 7-11: A five-beat 16-bit-sized transaction starting at address

If the transaction were aligned to a start address of $0x00$, the result would be a five-beat burst with a width of two bytes giving a maximum data transfer of 10 bytes. In this example, the first transfer starts at an unaligned address of $0x03$ and contains one byte. All the following transfers in the burst are aligned with the bus width and are composed of two bytes each.

The AXI protocol does not require the subordinate to take special action based on any alignment information from the manager.

Endianness support

The AXI protocol supports mixed-endian structures in the same memory space by using Big Endian-8 (BE-8) mode. Compared to little-endian mode, the same byte lanes are used in BE-8 mode, but the order of the bytes is reversed.



Mixed-endian structures using BE-32 are more complicated than those using BE-8, because byte lanes are not the same as little-endian mode.

The following example shows both little-endian and big-endian representations of the same four-byte word:

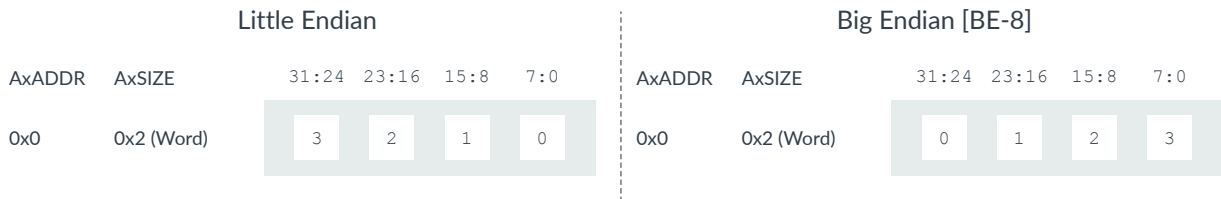
Figure 7-12: Little-endian and big-endian representations of the same four-byte word

For a four-byte word in little-endian mode, the most significant byte uses the most significant byte lane, which is byte lane 3. In BE-8 mode, the most significant byte uses the least significant byte lane, which is byte lane 0.

The following example shows both little-endian and big-endian representations of the same two-byte word:

Figure 7-13: Little-endian and big-endian representations of the same two-byte word

For a halfword of two bytes in little-endian mode, the most significant byte uses byte lane 1, and the least significant byte uses byte lane 0. Again, in big-endian BE-8 mode, the lanes that are used by the two bytes are switched. The most significant byte uses byte lane 0, and least significant byte uses byte lane 1.

Finally, for a single byte, there is no difference between little-endian and big-endian mode, as shown in the following example:

Figure 7-14: For a single byte, there is no difference between little-endian and big-endian mode

In both cases, the byte uses byte lane 0.

In a configurable endianness component like an Arm core, which supports BE-8, the reordering of the bytes should be performed internally, so that nothing has to be done at the interconnect level. On the other hand, a custom device that is connected to the AXI interconnect, which is BE-8 by

nature, would already have the correct order of bytes. Having BE-8 in the AXI protocol eases the support for dynamic endianness switching.

Read and write interface attributes

This section of the guide highlights some of the most important attributes for configuring AXI write and read channels.

The write interface attributes include the following:

- Write issuing capability: Represents the maximum number of active write transactions the manager interface can generate
- Write interleave capability (AXI3 only): The number of active write transactions for which the manager interface is capable of transmitting data.
- Write acceptance capability (AXI3 only): Represents the maximum number of active write transactions the subordinate interface can accept
- Write interleave depth attribute: Represents the number of active write transactions that the subordinate interface can receive data from

The read interface attributes include the following:

- Read issuing capability attribute: Represents the maximum number of active read transactions that a manager interface can generate
- Read acceptance capability: The maximum number of active read transactions that a subordinate interface can accept
- Read data reordering depth: The number of active read transactions for which a subordinate interface can transmit data, counted from the earliest transaction

8. Check your knowledge

Q: What burst type must a manager issue if it wants to write to a FIFO: fixed, wrapping, or incrementing?

A: Fixed. A FIFO works by writing to and reading from a fixed address.

Q: All AXI4 channels share the same handshake mechanism. The VALID signal goes from the source to the destination to indicate when valid information is available. Which signal goes from the destination to the source to indicate when it can accept information?

A: The READY signal.

Q: What is the purpose of transfer IDs?

A: Marking transactions with different IDs allows transactions with different IDs to complete out of order. This means that transactions to faster memory regions can complete without waiting for earlier transactions to slower memory regions.

9. Related information

Here are some resources related to material in this guide:

- [AMBA specifications](#)
- [AMBA on Arm developer](#)
- Arm video tutorials:
 - [AXI channels](#)
 - [AXI's main features](#)
 - [The AXI protocol](#)
 - [The AXI protocol in a multi-manager system design](#)
 - [Introduction to the AMBA AXI protocol](#)
 - [What is AMBA, and why use it?](#)

10. Next steps

This guide has provided an overview of the main topics relating to AMBA AXI, including the use and operation of the different channels and signals.

This knowledge will be useful as you learn more about AMBA AXI by reading the [AMBA AXI and ACE protocol specification](#). You can put your knowledge into action to develop interfaces that implement the AMBA AXI protocol.