

# Arm<sup>®</sup> Cortex<sup>®</sup>-M3 DesignStart<sup>™</sup> FPGA- Xilinx edition

Revision: r0p0

**User Guide**

The logo for Arm, consisting of the lowercase letters 'arm' in a bold, sans-serif font.

**Arm® Cortex®-M3 DesignStart™ FPGA-Xilinx edition****User Guide**

Copyright © 2018 Arm Limited or its affiliates. All rights reserved.

**Release Information****Document History**

Issue	Date	Confidentiality	Change
0000-00	29 October 2018	Non-Confidential	First release for r0p0.

**Non-Confidential Proprietary Notice**

This document is protected by copyright and other related rights and the practice or implementation of the information contained in this document may be protected by one or more patents or pending patent applications. No part of this document may be reproduced in any form by any means without the express prior written permission of Arm. **No license, express or implied, by estoppel or otherwise to any intellectual property rights is granted by this document unless specifically stated.**

Your access to the information in this document is conditional upon your acceptance that you will not use or permit others to use the information for the purposes of determining whether implementations infringe any third party patents.

THIS DOCUMENT IS PROVIDED “AS IS”. ARM PROVIDES NO REPRESENTATIONS AND NO WARRANTIES, EXPRESS, IMPLIED OR STATUTORY, INCLUDING, WITHOUT LIMITATION, THE IMPLIED WARRANTIES OF MERCHANTABILITY, SATISFACTORY QUALITY, NON-INFRINGEMENT OR FITNESS FOR A PARTICULAR PURPOSE WITH RESPECT TO THE DOCUMENT. For the avoidance of doubt, Arm makes no representation with respect to, and has undertaken no analysis to identify or understand the scope and content of, third party patents, copyrights, trade secrets, or other rights.

This document may include technical inaccuracies or typographical errors.

TO THE EXTENT NOT PROHIBITED BY LAW, IN NO EVENT WILL ARM BE LIABLE FOR ANY DAMAGES, INCLUDING WITHOUT LIMITATION ANY DIRECT, INDIRECT, SPECIAL, INCIDENTAL, PUNITIVE, OR CONSEQUENTIAL DAMAGES, HOWEVER CAUSED AND REGARDLESS OF THE THEORY OF LIABILITY, ARISING OUT OF ANY USE OF THIS DOCUMENT, EVEN IF ARM HAS BEEN ADVISED OF THE POSSIBILITY OF SUCH DAMAGES.

This document consists solely of commercial items. You shall be responsible for ensuring that any use, duplication or disclosure of this document complies fully with any relevant export laws and regulations to assure that this document or any portion thereof is not exported, directly or indirectly, in violation of such export laws. Use of the word “partner” in reference to Arm’s customers is not intended to create or refer to any partnership relationship with any other company. Arm may make changes to this document at any time and without notice.

If any of the provisions contained in these terms conflict with any of the provisions of any click through or signed written agreement covering this document with Arm, then the click through or signed written agreement prevails over and supersedes the conflicting provisions of these terms. This document may be translated into other languages for convenience, and you agree that if there is any conflict between the English version of this document and any translation, the terms of the English version of the Agreement shall prevail.

The Arm corporate logo and words marked with ® or ™ are registered trademarks or trademarks of Arm Limited (or its subsidiaries) in the US and/or elsewhere. All rights reserved. Other brands and names mentioned in this document may be the trademarks of their respective owners. Please follow Arm’s trademark usage guidelines at <http://www.arm.com/company/policies/trademarks>.

Copyright © 2018 Arm Limited (or its affiliates). All rights reserved.

Arm Limited. Company 02557590 registered in England.

110 Fulbourn Road, Cambridge, England CB1 9NJ.

LES-PRE-20349

**Confidentiality Status**

This document is Non-Confidential. The right to use, copy and disclose this document may be subject to license restrictions in accordance with the terms of the agreement entered into by Arm and the party that Arm delivered this document to.

Unrestricted Access is an Arm internal classification.

**Product Status**

The information in this document is Final, that is for a developed product.

**Web Address**

<http://www.arm.com>

# Contents

## Arm® Cortex®-M3 DesignStart™ FPGA-Xilinx edition User Guide

### **Preface**

<i>About this book</i> .....	7
<i>Feedback</i> .....	9

### **Chapter 1**

#### **Introduction**

1.1	<i>Cortex®-M3 DesignStart™ FPGA-Xilinx edition package</i> .....	1-11
1.2	<i>Directory structure</i> .....	1-12
1.3	<i>Cortex®-M3 processor integration</i> .....	1-13

### **Chapter 2**

#### **Installing the Cortex®-M3 DesignStart™ example design**

2.1	<i>Installing board files</i> .....	2-15
2.2	<i>Setting local drive for Windows</i> .....	2-17
2.3	<i>Installing Arm IP repository</i> .....	2-18
2.4	<i>Installing Arm software repository</i> .....	2-19
2.5	<i>Downloading QSPI memory models</i> .....	2-21
2.6	<i>Configuring simulation in Vivado</i> .....	2-23

### **Chapter 3**

#### **Cortex®-M3 processor IP configuration**

3.1	<i>Configuration tab</i> .....	3-25
3.2	<i>Debug tab</i> .....	3-27
3.3	<i>Instruction Memory tab</i> .....	3-29
3.4	<i>Data Memory tab</i> .....	3-31

3.5	Cortex®-M3 processor signals .....	3-33
<b>Chapter 4</b>	<b>Working with the Cortex®-M3 DesignStart™ example design</b>	
4.1	Editing the A7 example design .....	4-36
4.2	Debug .....	4-37
4.3	Memory map .....	4-38
4.4	QSPI multiplexing for the V2C-DAPLink board .....	4-41
4.5	Interrupt mapping .....	4-42
4.6	Constraints .....	4-43
4.7	Loading the pre-built bitstream .....	4-44
4.8	Loading the flash file .....	4-45
4.9	Bit file regeneration .....	4-47
4.10	Simulation .....	4-48
<b>Chapter 5</b>	<b>V2C-DAPLink board</b>	
5.1	V2C-DAPLink adaptor board features .....	5-50
5.2	V2C-DAPLink configuration .....	5-52
5.3	Flash download requirements .....	5-53
5.4	V2C-DAPLink board layout .....	5-54
5.5	Conditions to enable the DAP interface .....	5-56
5.6	DAP drivers .....	5-57
5.7	Programming the V2C-DAPLink QSPI using drag and drop .....	5-58
5.8	Using the µVision debugger to communicate through V2C-DAPLink .....	5-60
5.9	Using the µVision debugger to download projects through the flash programming utility .....	5-62
5.10	Recovering the DAP connection .....	5-65
<b>Chapter 6</b>	<b>Example software design</b>	
6.1	Example software design for Arty A7 .....	6-68
6.2	Example software design directory structure .....	6-69
6.3	Example design reference files .....	6-70
6.4	Generating the Arty A7 board support package .....	6-71
6.5	Building the example software design .....	6-77
6.6	Software update flow .....	6-78
<b>Appendix A</b>	<b>Revisions</b>	
A.1	Revisions .....	Appx-A-81

# Preface

This preface introduces the *Arm® Cortex®-M3 DesignStart™ FPGA-Xilinx edition User Guide*.

It contains the following:

- *About this book* on page 7.
- *Feedback* on page 9.

## About this book

This book describes how to use the Cortex®-M3 DesignStart™ FPGA-Xilinx edition to design your system using the Cortex-M3 processor. This book also describes an example design for the Digilent Arty *Artix 7* (A7) development board.

### Product revision status

The *rm**pn* identifier indicates the revision status of the product described in this book, for example, r1p2, where:

*rm* Identifies the major revision of the product, for example, r1.

*pn* Identifies the minor revision or modification status of the product, for example, p2.

### Intended audience

The intended audience is system designers, system integrators, and verification engineers who want to implement the processor in a *Field-Programmable Gate Array* (FPGA) using the Xilinx Vivado tools.

### Using this book

This book is organized into the following chapters:

#### **Chapter 1 Introduction**

The Cortex-M3 DesignStart™ FPGA-Xilinx edition package provides an easy way to use the Cortex-M3 processor in the Xilinx Vivado design environment. The Cortex-M3 processor is intended for deeply embedded applications, usually in ASIC designs. It can be implemented in FPGA, but is not optimized for timing. The processor implements the Armv7-M architecture.

#### **Chapter 2 Installing the Cortex®-M3 DesignStart™ example design**

This chapter describes the Cortex-M3 DesignStart example design installation process.

#### **Chapter 3 Cortex®-M3 processor IP configuration**

After installing the Arm *IP Integrator* (IPI) repository, you can find the Cortex-M3 processor package in the Vivado IP catalog.

#### **Chapter 4 Working with the Cortex®-M3 DesignStart™ example design**

This chapter describes how to work with an example design targeting a low-cost evaluation board, Digilent Arty *Artix 7* (A7). This example design is provided to demonstrate the integration and software development using the Cortex-M3 processor. The example is based on the Digilent Arty A7-35T board, and uses some of the standard Xilinx peripherals to connect to some of the features on the board. The example is intended to show typical usage, rather than a completely minimal Cortex-M3 processor design.

#### **Chapter 5 V2C-DAPLink board**

The optional V2C-DAPLink adaptor board provides a debug flow that is familiar to anyone who is used to working with Cortex-M microcontrollers. It allows Arty FPGA boards to be used with mbed OS 2 Classic. This chapter describes the optional V2C-DAPLink adaptor board and how it is used.

#### **Chapter 6 Example software design**

This chapter describes an example software design, and describes how to build and debug it.

#### **Appendix A Revisions**

This appendix describes the technical changes between released issues of this document.

### Glossary

The Arm® Glossary is a list of terms used in Arm documentation, together with definitions for those terms. The Arm Glossary does not contain terms that are industry standard unless the Arm meaning differs from the generally accepted meaning.

See the *Arm® Glossary* for more information.

## Typographic conventions

### *italic*

Introduces special terminology, denotes cross-references, and citations.

### **bold**

Highlights interface elements, such as menu names. Denotes signal names. Also used for terms in descriptive lists, where appropriate.

### monospace

Denotes text that you can enter at the keyboard, such as commands, file and program names, and source code.

### monospace

Denotes a permitted abbreviation for a command or option. You can enter the underlined text instead of the full command or option name.

### *monospace italic*

Denotes arguments to monospace text where the argument is to be replaced by a specific value.

### **monospace bold**

Denotes language keywords when used outside example code.

### <and>

Encloses replaceable terms for assembler syntax where they appear in code or code fragments. For example:

```
ADD Rd, SP, #<imm>
```

### SMALL CAPITALS

Used in body text for a few terms that have specific technical meanings, that are defined in the *Arm® Glossary*. For example, IMPLEMENTATION DEFINED, IMPLEMENTATION SPECIFIC, UNKNOWN, and UNPREDICTABLE.

## Additional reading

This book contains information that is specific to this product. See the following documents for other relevant information.

### Arm publications

- *Cortex®-M3 Technical Reference Manual* (100165).
- *Arm® CoreSight™ SoC-400 Technical Reference Manual* (DDI 0480).

The following confidential book is only available to licensees:

*Cortex®-M3 Integration and Implementation Manual* (DII 0240B).

### Other publications

- IEEE Std 1149.1-2001, *Test Access Port and Boundary-Scan Architecture (JTAG)*.
- ANSI/IEEE Std 754-2008, *IEEE Standard for Binary Floating-Point Arithmetic*.



## Feedback

### Feedback on this product

If you have any comments or suggestions about this product, contact your supplier and give:

- The product name.
- The product revision or version.
- An explanation with as much information as you can provide. Include symptoms and diagnostic procedures if appropriate.

### Feedback on content

If you have comments on content then send an e-mail to [errata@arm.com](mailto:errata@arm.com). Give:

- The title *Arm Cortex-M3 DesignStart FPGA-Xilinx edition User Guide*.
- The number 101483\_0000\_00\_en.
- If applicable, the page number(s) to which your comments refer.
- A concise explanation of your comments.

Arm also welcomes general suggestions for additions and improvements.

————— **Note** —————

Arm tests the PDF only in Adobe Acrobat and Acrobat Reader, and cannot guarantee the quality of the represented document when used with any other PDF reader.

---

# Chapter 1

## Introduction

The Cortex-M3 DesignStart™ FPGA-Xilinx edition package provides an easy way to use the Cortex-M3 processor in the Xilinx Vivado design environment. The Cortex-M3 processor is intended for deeply embedded applications, usually in ASIC designs. It can be implemented in FPGA, but is not optimized for timing. The processor implements the Armv7-M architecture.

This chapter describes the Cortex-M3 DesignStart FPGA-Xilinx edition features and directory structure.

It contains the following sections:

- [1.1 Cortex®-M3 DesignStart™ FPGA-Xilinx edition package on page 1-11.](#)
- [1.2 Directory structure on page 1-12.](#)
- [1.3 Cortex®-M3 processor integration on page 1-13.](#)

## 1.1 Cortex®-M3 DesignStart™ FPGA-Xilinx edition package

An example system design is provided to target a low-cost development platform, with example integration tests.

The Cortex-M3 DesignStart FPGA-Xilinx edition package includes:

- A Cortex-M3 processor that has:
  - A *Nested Vectored Interrupt Controller* (NVIC) that supports up to 240 interrupts, each with up to 256 levels of priority that can be changed dynamically.
  - Configurable endianness, only little-endian is supported in the example system.
  - Configurable embedded debug support.
  - *Instruction Tightly Coupled Memory* (ITCM), up to 1MB.
  - *Data Tightly Coupled Memory* (DTCM), up to 1MB.
  - ITCM Alias support.
  - *Serial Wire* (SW), JTAG, or combined SWJ-DP debug port.
- Integrated AHB to AXI bridges, which allow the packaged Cortex-M3 processor to connect directly to standard Vivado components.
- Optional *Embedded Trace Macrocell* (ETM) for instruction trace, *Data Watchpoint and Trace* (DWT) and *Instrumentation Trace Macrocell* (ITM), coupled with a *Trace Port Interface Unit* (TPIU) with four pins.
- Optional V2C-DAPLink board support, which:
  - Provides Cortex-M debug flow.
  - V2C-DAPLink USB to the *Serial Wire Debug* (SWD) interface.
  - V2C-DAPLink USB UART endpoint.
  - Local *Quad Serial Peripheral Interface* (QSPI), flash for code download (8MB) independent of FPGA image.
  - User accessible microSD card support.
  - Pass-through connections for shield adapter boards.
- Example designs for Arty *Artix 7* (A7) 35T development boards.
  - Integrates the processor with standard Xilinx peripherals.
  - Example software tests.
- *Cortex Microcontroller Software Interface Standard* (CMSIS) compatible *Board Support Package* (BSP) generation that is done through Xilinx Vivado *Software Development Kit* (SDK).
- Support for simulation and FPGA implementation. The encrypted design can be:
  - Simulated in the Xilinx Vivado and Mentor QuestaSim simulators.
  - Implemented for FPGA in Xilinx Vivado.

---

### Note

The Cortex-M3 DesignStart FPGA-Xilinx edition package:

- Can be used with any suitable Xilinx FPGA, but the example system design only supports one specific development board. You require version 2018.2 or later of the Xilinx Vivado tool.
- Targets Windows development environment and uses Arm Keil *Microcontroller Development Kit* (MDK) for software development.

---

To use the example system designs, you require:

- A Digilent Arty A7 development board or a supported Xilinx FPGA.
- The board files provided by Digilent for this board or support files for any board that you use.
- Xilinx Vivado.
- Arm Keil MDK or a Cortex-M compatible toolchain.

## 1.2 Directory structure

The expected directory structure after you download and unpack the Arm IP deliverables is:

```
<installation_directory>
|_docs
|_hardware/
|   |_m3_for_arty_a7/
|       |_block_diagram/
|           |_constraints/
|               |_m3_for_arty_a7/
|                   |_testbench/
|_software/
|   |_m3_for_arty_a7/
|       |_Build_Keil/
|           |_flash_downloader/
|_vivado/
|   |_Arm_ipi_repository/
|       |_CM3DbgAXI/
|           |_DAPLink_to_Arty_shield/
|   |_Arm_sw_repository/
|       |_Cortex-M
```

The following table describes the directory structure.

**Table 1-1 Directory structure**

File	Description
/docs	Contains this document and example design diagram.
hardware/m3_for_arty_a7/block_diagram/	Example block diagram.
hardware/m3_for_arty_a7/constraints/	Constraint files.
hardware/m3_for_arty_a7/m3_for_arty_a7/	Vivado project root.
hardware/m3_for_arty_a7/testbench/	Simulation testbench.
software/m3_for_arty_a7/	Example software application.
software/m3_for_arty_a7/Build_Keil/	Compilation directory for example code, which compiles under MDK and uses Xilinx drivers.
software/flash_downloader/	Flash downloader.
vivado/Arm_ipi_repository/CM3DbgAXI/	Cortex-M3 processor debug and AXI interface.
vivado/Arm_ipi_repository/ DAPLink_to_Arty_shield/	Interface block to the Arty adaptor board.
vivado/Arm_sw_repository/	Cortex-M3 processor software files for <i>Board Support Package (BSP)</i> and example application development.

Before you can use the deliverables, you must configure your Vivado installation to:

- Reference the Arm IP.
- Install the Digilent board files, if you want to use the provided example design.

————— **Note** —————

If you have already installed other Arm DesignStart FPGA-Xilinx products, then these have a similar directory structure. Arm recommends that you merge the directory structure between the installs to simplify their use. At a minimum, Arm recommends that you merge the directories under /vivado so that Vivado only needs to be assigned one directory location to read Arm hardware and software repositories.

### 1.3 Cortex®-M3 processor integration

The Cortex-M3 processor which is included in the Cortex-M3 DesignStart FPGA-Xilinx edition deliverables has been pre-integrated with several components to make it easier to use in an FPGA flow.

There are two *Tightly Coupled Memory* (TCM) instances, for code and data. These are both configurable in size. The *Instruction Tightly Coupled Memory* (ITCM) can be configured at run time to be aliased to either or both of  $0x00000000$  and  $0x10000000$ . The *Data Tightly Coupled Memory* (DTCM) is at a fixed location of  $0x20000000$ .

The instruction code and data code AHB interfaces from the processor are combined internally. Any access from either of these buses which does not match an active ITCM alias is presented on the external instruction AXI interface.

The *System AHB* (S-AHB) interface from the processor is used to access the DTCM, any accesses which are not within the range of the configured DTCM size are presented on the system AXI interface.

The processor is integrated with a *Serial Wire/JTAG Debug Port* (SWJ-DP) to provide debug access.

The following figure shows internal memory processing of the instruction code and data code AHB interfaces.

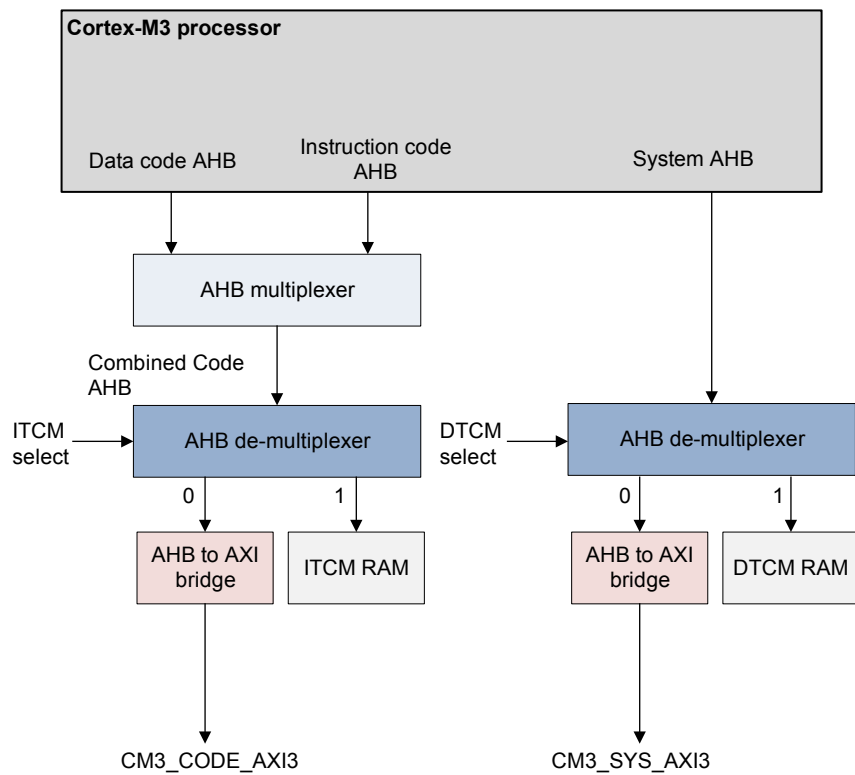

Figure 1-1 Internal memory processing

# Chapter 2

## Installing the Cortex<sup>®</sup>-M3 DesignStart<sup>™</sup> example design

This chapter describes the Cortex-M3 DesignStart example design installation process.

———— **Attention** ————

If you only use the provided example design for software development, then you can skip [2.5 Downloading QSPI memory models](#) on page 2-21 and [2.6 Configuring simulation in Vivado](#) on page 2-23. You can use the steps described in [4.8 Loading the flash file](#) on page 4-45 to load the FPGA image.

It contains the following sections:

- [2.1 Installing board files](#) on page 2-15.
- [2.2 Setting local drive for Windows](#) on page 2-17.
- [2.3 Installing Arm IP repository](#) on page 2-18.
- [2.4 Installing Arm software repository](#) on page 2-19.
- [2.5 Downloading QSPI memory models](#) on page 2-21.
- [2.6 Configuring simulation in Vivado](#) on page 2-23.

## 2.1 Installing board files

The Digilent Arty *Artix 7* (A7) board uses a board file to enable easy connectivity from the Xilinx *IP Integrator* (IPI) tool to the board pins. To use the board file in the tool, you must copy the board file into the Vivado installation.

### Caution

If you have opened the example design before the board files were installed, then Vivado has already modified the project to only target the device and not the board. In this scenario, when the example design block diagram is opened, Vivado reports errors because it does not have the board I/O connections. To resolve this, you must copy the Xilinx project file (`m3_for_arty_a7.xpr`) again from the archive.

### Procedure

- The board file download and installation instructions are found at <https://reference.digilentinc.com/learn/software/tutorials/vivado-board-files/start>. As a minimum you must install the `/arty` directory.
- To use the board files in a shared environment, you can add a reference to the location as part of your design. For example, if you uncompress the Digilent files to `<install_dir>/vivado/Digilent`, you can use the following command in the Tcl console.

```
set_param board.repoPaths ../../vivado/Digilent_board_files/vivado-boards-master/new/  
board_files/arty/
```

- Alternatively, the Vivado project has the parameter `board.repoPaths` ready within it. Open the Vivado project, `<install_dir>/hardware/m3_for_arty_a7/m3_for_arty_a7/m3_for_arty_a7.xpr`, and uncomment the following line:

```
<!-- Option Name="BoardPartRepoPaths" Val="$PPRDIR/../../vivado/Digilent_board_files/  
vivado-boards-master/new/board_files"/ -->
```

When the design is opened in Vivado and if the board files are not correctly installed, the following error message is displayed.

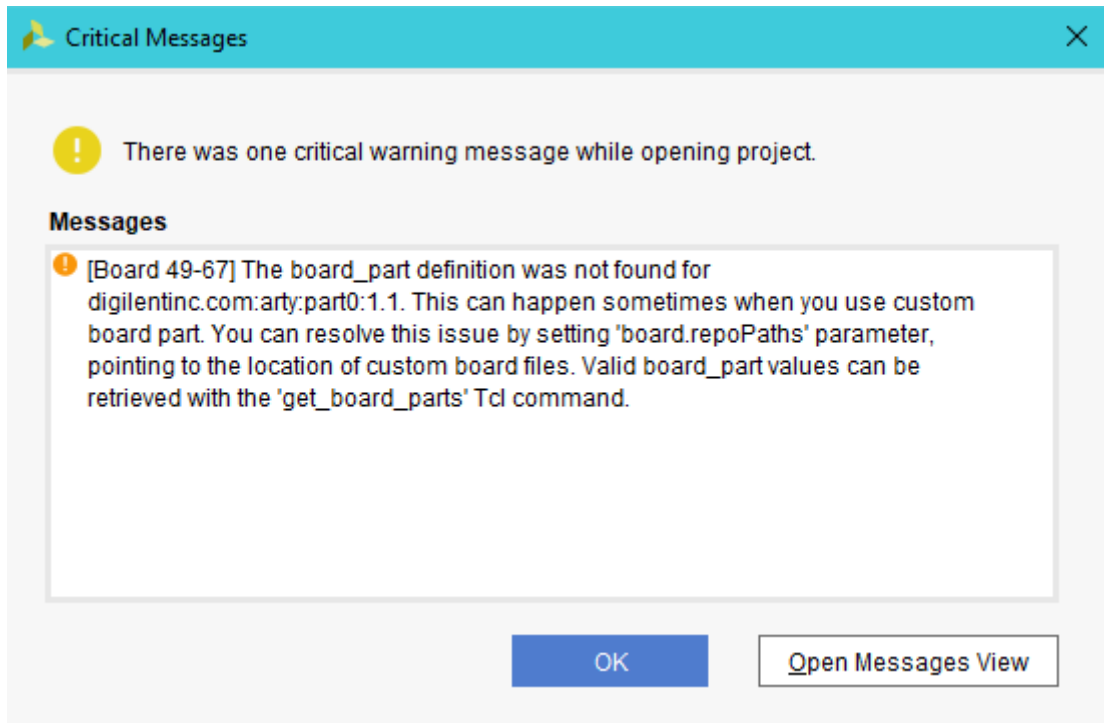

Figure 2-1 Error message

### Next Steps

You must now proceed to [2.2 Setting local drive for Windows](#) on page 2-17 .



## 2.2 Setting local drive for Windows

Some Vivado projects can have issues with long path names to instances deep within the hierarchy because of Windows limitations on path length. This can become apparent when running simulations and other processes.

To resolve this, when running in Windows, Arm recommends that you assign a drive letter to the root of the current design. Using this method, all subsequent paths are relative to this drive letter. To map a local drive letter to the current path:

### Prerequisites

You must complete the steps in [2.1 Installing board files on page 2-15](#).

### Procedure

1. Open Vivado.
2. Open the Tcl console window.
3. The current directory location can be checked using the Unix command `pwd`.
4. Navigate to your `<installation_directory>` folder. This is the folder where the Cortex-M3 package was installed.
5. To map the `<installation_directory>` folder to the drive `V:`, type the following command in the prompt:

```
exec subst V: .
```

#### Attention

In the `exec subst V: .` command, you must add a space between `V:` and `.` characters.

The package `<installation_directory>` folder maps to drive `V:` and the rest of this book assumes that this folder maps to drive `V:`. If you map to a different drive, you must use the different drive in the instructions as appropriate. If the drive mapping is successful, you should have the directories `V:/hardware`, `V:/software`, `V:/vivado`, and `V:/docs`.

### Next Steps

You must now proceed to [2.3 Installing Arm IP repository on page 2-18](#).

## 2.3 Installing Arm IP repository

After downloading and unpacking the deliverable, the Arm *IP Integrator* (IPI) repository must be added to the list of Vivado IP repositories. This makes the processor available in any new designs.

To add Arm IPI repository to the list of Vivado IP repositories:

### Prerequisites

You must complete the steps in:

- [2.1 Installing board files on page 2-15.](#)
- [2.2 Setting local drive for Windows on page 2-17.](#)

### Procedure

1. Open Vivado.
2. From Tools → Settings, select IP Defaults.
3. In the list of Default IP repository search paths, add the path to the `/Arm_ipi_repository`.

Vivado only reads the IPI repository during design creation. If the repository is updated, or an existing design must use the Cortex-M3 processor, then you must refresh the project repository. To do this, navigate to Tools → Settings → IP → Repository → Refresh all.

### Next Steps

You must now proceed to [2.4 Installing Arm software repository on page 2-19.](#)

## 2.4 Installing Arm software repository

The Arm software repository must also be added to the list of available Vivado repositories.

To add the Arm software repository to the list of Vivado software repositories:

### Prerequisites

You must complete the steps in:

- [2.1 Installing board files](#) on page 2-15.
- [2.2 Setting local drive for Windows](#) on page 2-17.
- [2.3 Installing Arm IP repository](#) on page 2-18.

### Procedure

1. Open Vivado.
2. From File, select *Launch SDK*.
3. Set the default *Exported location* to `V:/software` and the default *Workspace* to `V:/software/m3_for_arty_a7/sdk_workspace`.

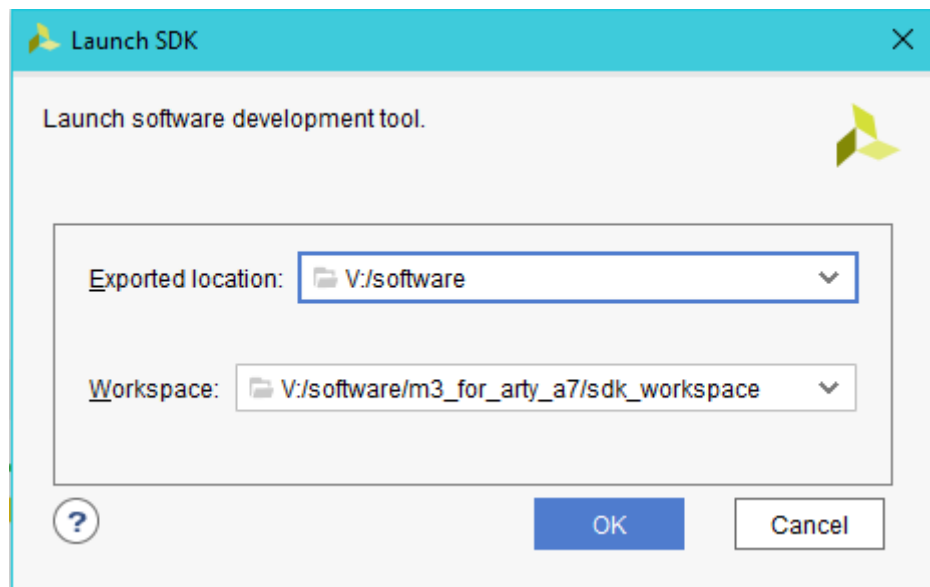

**Figure 2-2 Launch SDK**

4. Vivado issues a warning regarding the exported hardware file being out of date. This is because you have not built the project. Select Yes to proceed.

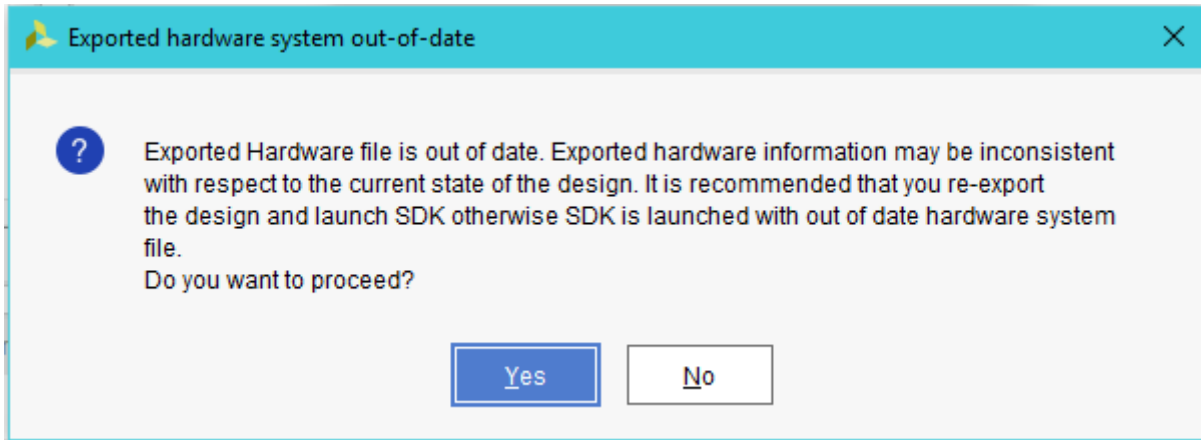

**Figure 2-3 Exported hardware system out-of-date**

5. Once the SDK opens, select Xilinx → Repositories and add the path to the V:vivado/Arm\_sw\_repository/ to the Global Repositories.

### Next Steps

To use the Cortex-M3 software on existing designs, you might be required to rescan the *Software Development Kit* (SDK) repositories. In the SDK, select Xilinx → Repositories → Rescan Repositories.

You must now proceed to [2.5 Downloading QSPI memory models](#) on page 2-21.

## 2.5 Downloading QSPI memory models

If you want to simulate the example design, then the testbench can also simulate the *Quad Serial Port Interface* (QSPI) devices that are fitted to the Arty *Artix 7* (A7) baseboard (a Micron device) and the V2C-DAPLink board (a Cypress device).

### Prerequisites

#### Note

It is only necessary to download the QSPI memory models if you want to simulate the example design when you are operating on the Arty A7 board, and optionally, with the V2C-DAPLink board fitted. If you do not want to simulate the design, you can ignore this section.

#### Caution

If you do not download the QSPI memory models, then you get warnings every time you open the Vivado project. The following figure shows these warnings. If you do not intend to simulate the QSPI models, then these warnings can be ignored.

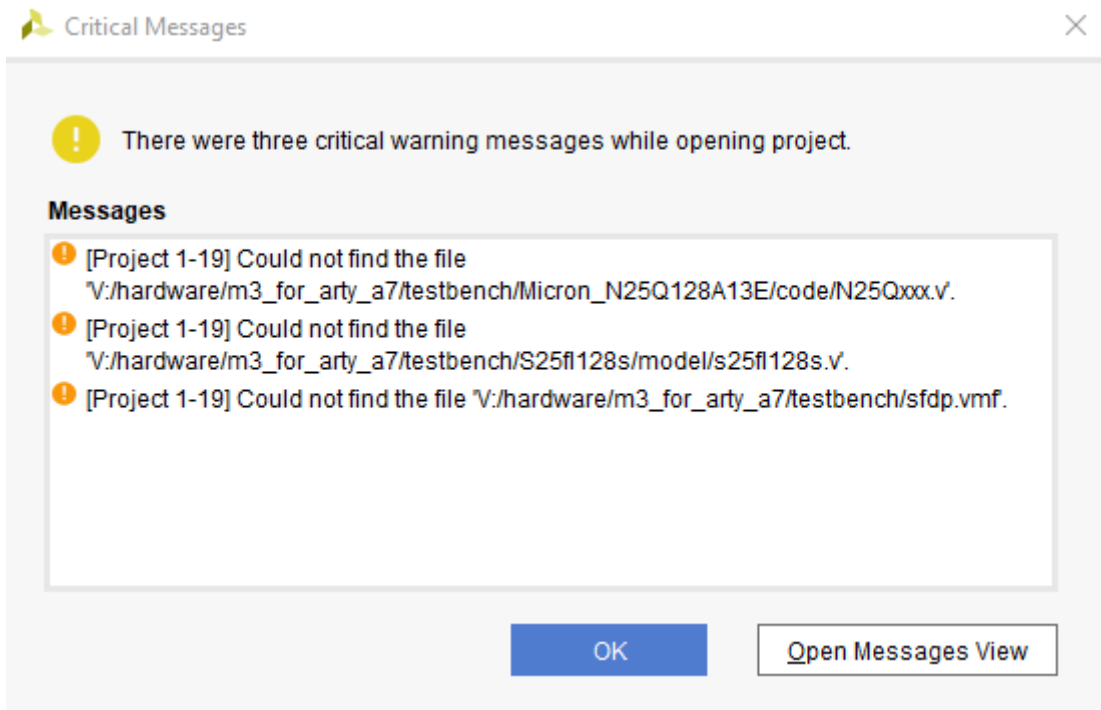

You must complete the steps in:

- [2.1 Installing board files](#) on page 2-15.
- [2.2 Setting local drive for Windows](#) on page 2-17.
- [2.3 Installing Arm IP repository](#) on page 2-18.
- [2.4 Installing Arm software repository](#) on page 2-19.

## Procedure

- To simulate the QSPI devices that are fitted, you must download the appropriate models from Micron and Cypress websites.
- When the QSPI memory models are correctly installed, you can enable using the Verilog define at the top of `V:/testbench/tb_m3_for_arty.v`.

If the V2C-DAPLink board is fitted and QSPI device models included, then code execution is from the QSPI device on the V2C-DAPLink board.

## Next Steps

You must first refer to the information in either of the following depending on the QSPI model that you choose to install:

- [2.5.1 Micron QSPI model on page 2-22.](#)
- [2.5.2 Cypress QSPI model on page 2-22.](#)

After you have downloaded and installed the required QSPI model, you must proceed to [2.6 Configuring simulation in Vivado on page 2-23.](#)

### 2.5.1 Micron QSPI model

The Micron device used on the Digilent Arty *Artix 7* (A7) base board is N25Q128A13E.

A Verilog simulation model for this device is available in the Micron website.

The archive file that you must download is `N25Q128A13E_3V_MicronXIP_VG12.tar`. When the archive is downloaded, it must be expanded to a directory named `/Micron_N25Q128A13E`. This directory must be located under the `V:/hardware/m3_for_arty_a7/testbench` directory. To enable the correct configuration of the QSPI memory, the `/Micron_N25Q128A13E/sim/sfdp.vmf` file must be copied to the `V:/hardware/m3_for_arty_a7/testbench` directory.

If you are using the Micron model, ensure to add the include directory for it to the design. This is done in the Tcl console using the following command:

```
set_property INCLUDE_DIRS [get_property DIRECTORY [current_project]]/./testbench/  
Micron_N25Q128A13E [get_filesets sim_1]
```

### 2.5.2 Cypress QSPI model

The Cypress (Spansion) QSPI device used on the V2C-DAPLink board is S25f1128S.

A Verilog simulation model for this device is available at the Cypress website.

The archive file that you must download is `s25f1128s.zip`. This archive is a self-installing executable. Run the executable, and extract the files to the `V:/hardware/m3_for_arty_a7/testbench` directory. This copies the model files to a folder called `/S25f1128s` in this location.

## 2.6 Configuring simulation in Vivado

To configure simulations in Vivado, you must have either the Vivado or a third-party simulator installed. The paths to the simulator must be configured in Vivado.

To configure the paths to the simulator in Vivado, navigate to Tools → Settings → Tool Settings → 3rd Party simulators.

### Prerequisites

- [2.1 Installing board files on page 2-15.](#)
- [2.2 Setting local drive for Windows on page 2-17.](#)
- [2.3 Installing Arm IP repository on page 2-18.](#)
- [2.4 Installing Arm software repository on page 2-19.](#)
- [2.5 Downloading QSPI memory models on page 2-21.](#)

# Chapter 3

## Cortex<sup>®</sup>-M3 processor IP configuration

After installing the Arm *IP Integrator* (IPI) repository, you can find the Cortex-M3 processor package in the Vivado IP catalog.

This package is a version of Cortex-M3 r2p1 processor with debug and two BP136 AHB to AXI bridges r0p1 pre-integrated.

See the *Cortex<sup>®</sup>-M3 Technical Reference Manual* for a detailed description of the processor.

This chapter describes the four Cortex-M3 processor IP configuration tabs, each with details on individual configuration categories.

---

**Note**

For more information about the Cortex-M3 processor configuration options, see, the *Configurable options* section in the *Cortex<sup>®</sup>-M3 Technical Reference Manual*.

---

It contains the following sections:

- [3.1 Configuration tab](#) on page 3-25.
- [3.2 Debug tab](#) on page 3-27.
- [3.3 Instruction Memory tab](#) on page 3-29.
- [3.4 Data Memory tab](#) on page 3-31.
- [3.5 Cortex<sup>®</sup>-M3 processor signals](#) on page 3-33.



### 3.1 Configuration tab

The following figure shows the configuration tab.

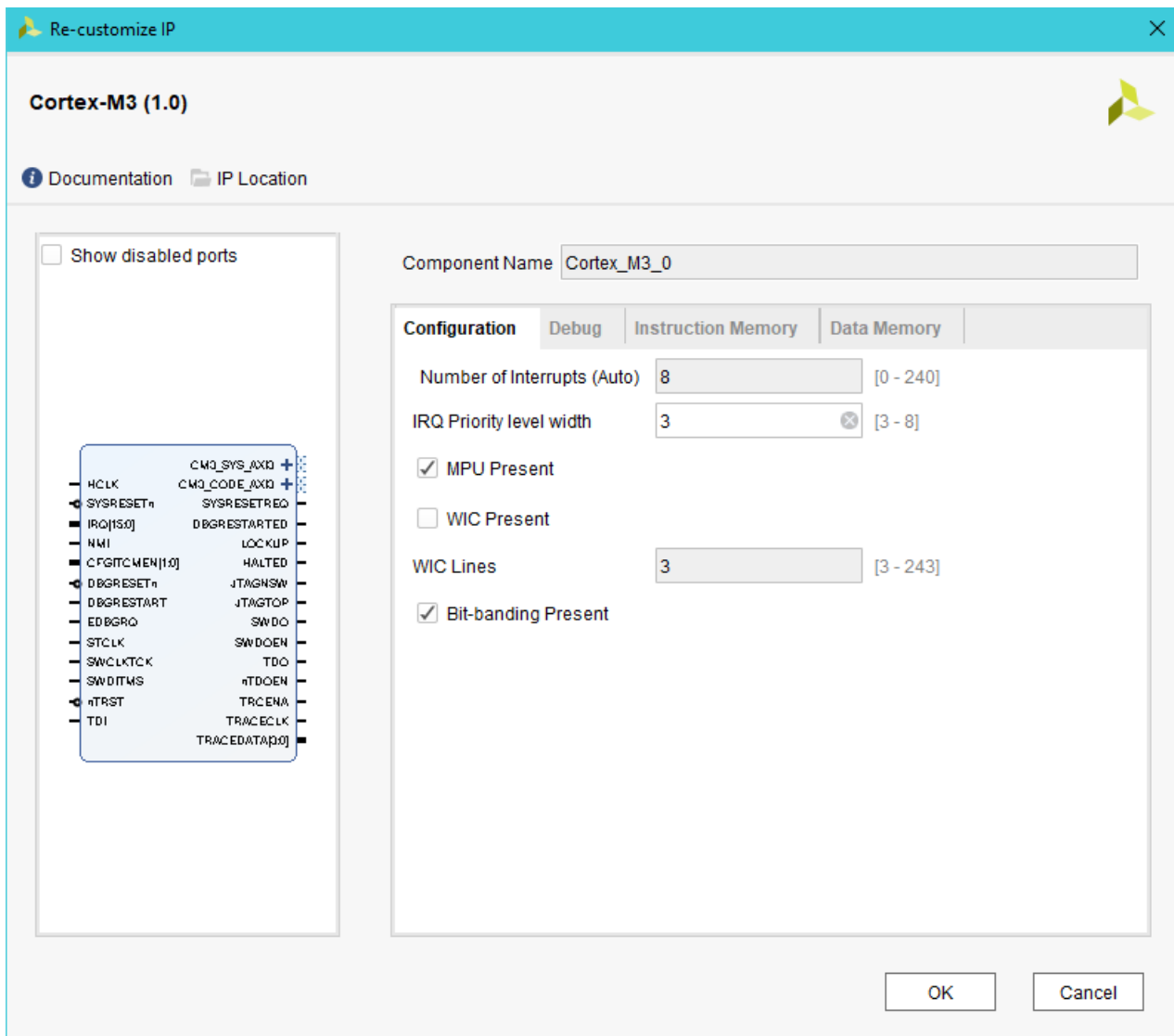

Figure 3-1 Configuration tab

In this tab, you can select the following:

### Number of interrupts

This indicates the number of interrupt sources the Cortex-M3 processor supports. The Cortex-M3 processor can support up to 240 interrupt sources.

The width of the signals connected to the IRQ port automatically determines the number of interrupts. This implies that you cannot set the value directly. To update the width of the IRQ port, connect the required number of signals to the IRQ port. You can then validate the block diagram. This updates the IRQ port width, and the configuration tab with the new value.

————— **Note** —————

Increasing the number of interrupts or the number of priority levels affects the maximum synthesis frequency.

---

### IRQ Priority level width

This determines the number of IRQ priority levels and is equal to  $2^{\text{Priority level width}}$ . The range is 3-8, with a default value of 3, that is, eight priority levels.

### MPU Present

Enable the *Memory Protection Unit* (MPU) in the Cortex-M3 core.

### WIC Present

Enable the *Wake-up Interrupt Controller* (WIC) in the Cortex-M3 core.

### WIC Lines

Determine the number of internal priority lines used for the WIC. This value can only be changed if the WIC present is enabled.

### Bit banding present

Enable bit-banding in the Cortex-M3 core.

For more information on these options, see the *Cortex®-M3 Technical Reference Manual*.

## 3.2 Debug tab

The following figure shows the Debug tab.

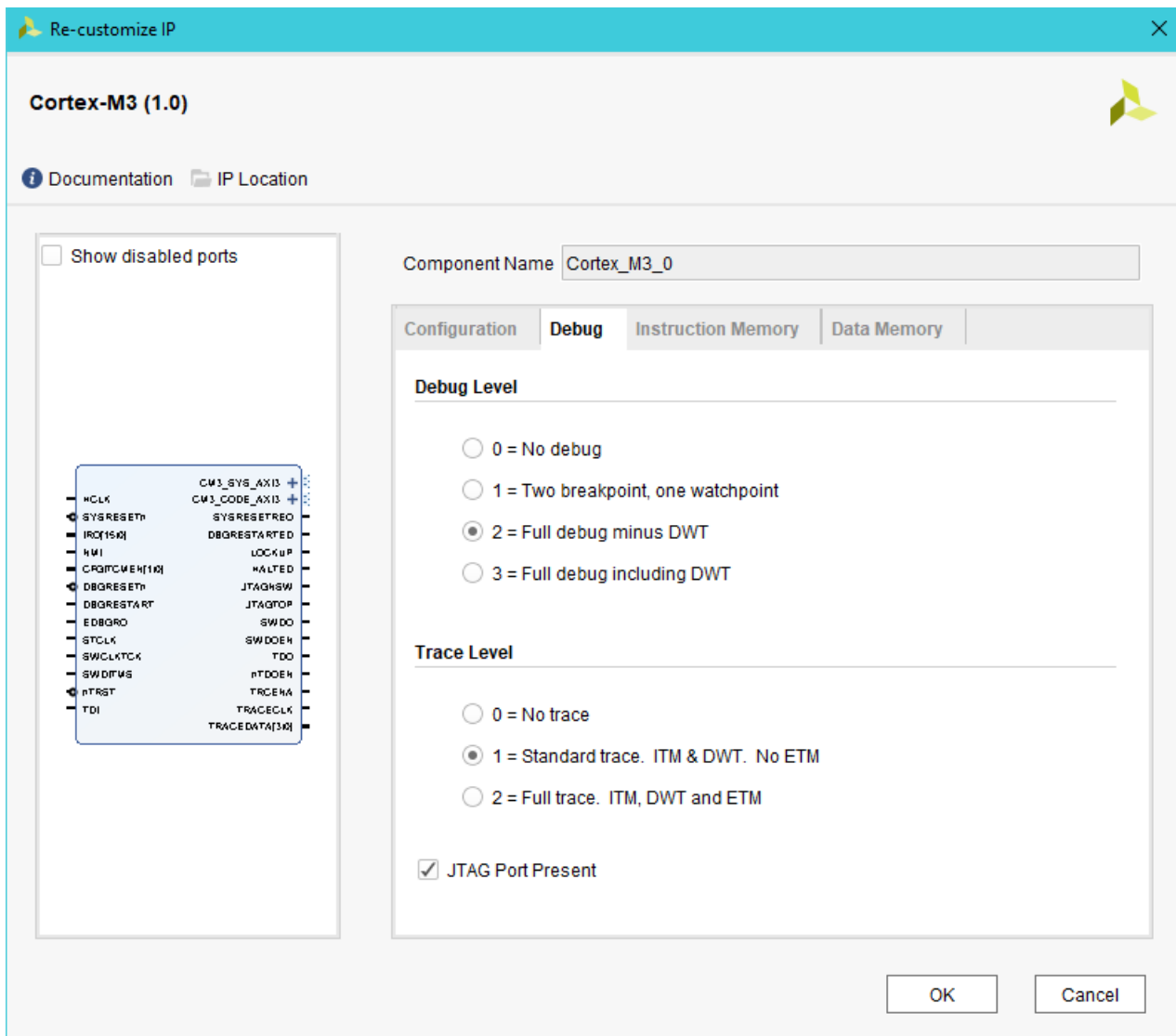

**Figure 3-2 Configuration tab**

On this tab you can select the following:

### Debug level

This enables you to set the level of debug supported.

————— **Note** —————

If this field is set to 0=No debug, the resulting build does not support the V2C-DAPLink board and it is not possible to drag and drop software to the V2C-DAPLink board.

### Trace level

This enables you to set the level of debug trace that is supported, that is, from no trace to full trace.

If the Debug level is set to 0=No debug, the Trace level is automatically set to 0. If the Debug level is set to any other value, then you must reset the Trace level to the required value.

### JTAG Present

When enabled, the debug port can be accessed using the Cortex-M3 JTAG pins.

————— **Note** —————

The debug port supports *Serial Wire* (SW) interface by default.

—————

For more information on these options, see the *Cortex®-M3 Technical Reference Manual*.

### 3.3 Instruction Memory tab

The following figure shows the Instruction Memory tab.

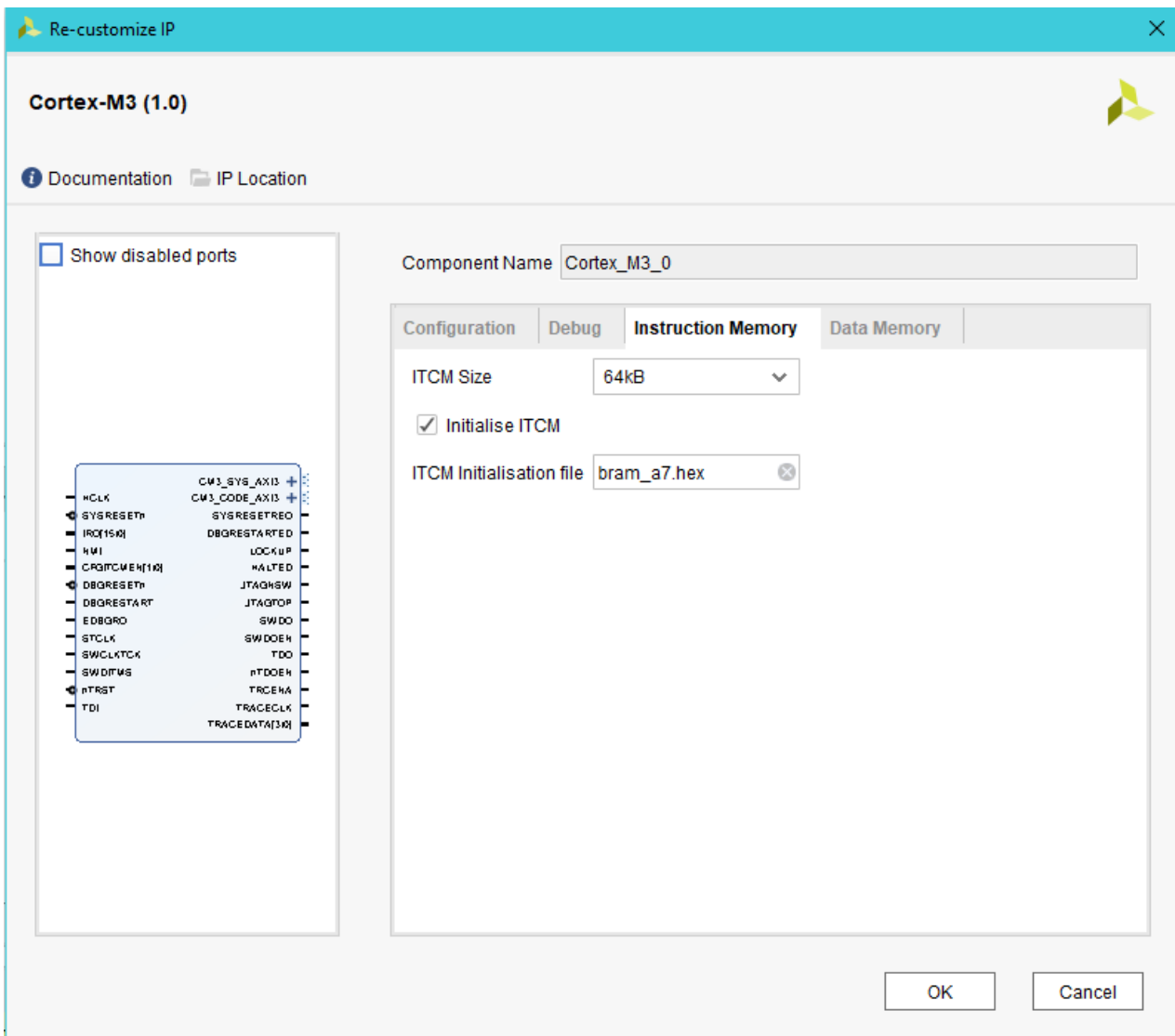

**Figure 3-3 Instruction Memory tab**

On this tab you can select the following:

#### ITCM Size

The range is 8KB to 1MB. Select the optimal size for your code base.

————— **Note** —————

- Currently the flow to update a bitstream with new *Instruction Tightly Coupled Memory* (ITCM) data only supports memory sizes in the range 16KB to 128KB. If you require sizes outside that range, contact Arm for support. For more information on this flow, see [Software Update flow on page 6-78](#).

### Initialize ITCM

If you require the instruction memory to be initialized when the design is built:

1. Select Initialize ITCM.
2. Specify the filename, see the example design as a reference.

————— **Note** —————

- The filename must not have quote marks around it.
- The filename must be added to the design and marked as a memory initialization file.
- Vivado reads the memory file during synthesis. It is not possible to update the memory file and to run just implementation or generate bitstream. To incorporate software updates into an existing bit file, see [Software Update flow on page 6-78](#).

ITCM aliasing is controlled at reset by the state of the **CFGITCMEN[1:0]** signal. For more information on **CFGITCMEN[1:0]**, see the The upper and lower aliases can be enabled independently, that is, either one alias, both aliases, or none of the aliases. For more information about processor memory regions, see the *Cortex®-M3 Technical Reference Manual*.

To boot the processor from ITCM, you must:

1. Enable ITCM lower alias.
2. Initialize the ITCM.

If the processor does not boot from ITCM, you must provide memory at address `0x00000000` on the external AXI interface which contains the initial stack pointer and vector table.

Instruction fetch latency is lower from ITCM than from the AXI interface. If you boot from AXI memory, you can copy code to ITCM at the upper alias and then execute from there to get better performance.

### 3.4 Data Memory tab

The following figure shows the data memory tab.

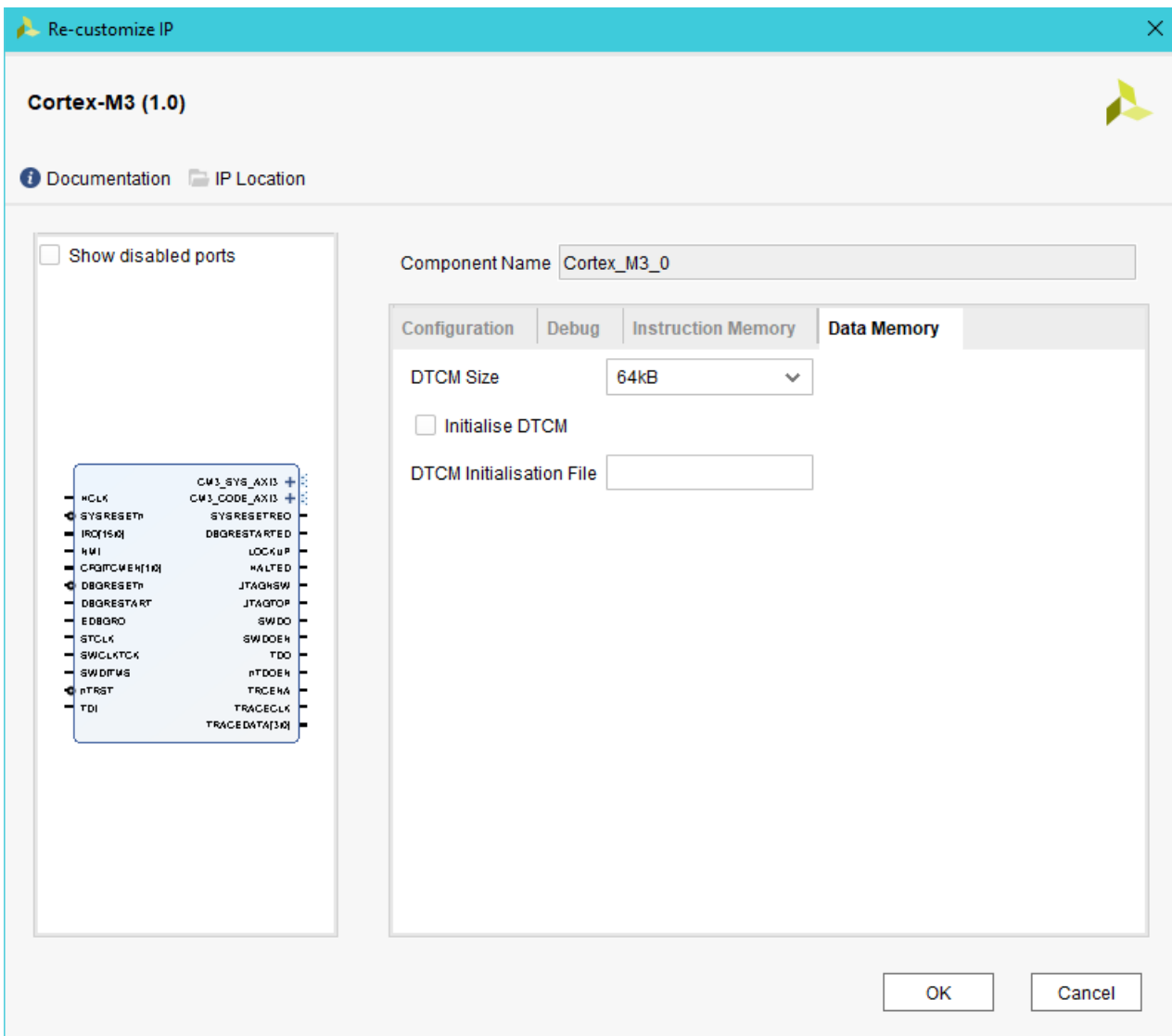

Figure 3-4 Data Memory tab

#### DTCM size

The range is 2KB to 1MB. Select the optimal size for your code base.

### Initialize DTCM

If you require the data memory to be initialized when the design is built:

1. Select Initialize DTCM checkbox.
2. Specify the filename, see the example design as a reference.

————— **Note** —————

- The filename must not have quote marks around it.
  - The filename must be added to the design and marked as a memory initialization file.
  - Vivado reads the memory file during synthesis. It is not possible to update the memory file and to run just implementation or generate bitstream. To incorporate software updates into an existing bit file, see [6.6 Software update flow on page 6-78](#).
-



## 3.5 Cortex®-M3 processor signals

For details of the Cortex-M3 signals, see the *Signal descriptions* appendix in the *Cortex®-M3 Technical Reference Manual*.

The three external AHB-Lite interfaces are not exported, and the two AXI interfaces replaces them. For more information, see [Figure 1-1 Internal memory processing on page 1-13](#).

The AHB-AP interface is not exported, it is replaced by the *Serial Wire* (SW) or JTAG interface pins that are described in the *Arm® CoreSight™ SoC-400 Technical Reference Manual*.

### **CFGITCMEN[1:0]**

This input signal is the *Instruction Tightly Coupled Memory* (ITCM) alias enable. Bit [1] sets the upper alias enable line and bit [0] sets the lower alias enable line. The value of this signal must be held constant for at least two cycles before SYSRESETn is deasserted.

If **CFGITCMEN[1]** is set, then the internal RAM ITCM is mapped to the upper address alias in the memory map.

If **CFGITCMEN[0]** is set, then the internal RAM ITCM is mapped to the lower address alias in the memory map.

Processor instruction fetches that are to memory addresses that are not aliased to the ITCM is output on the CM3\_CODE\_AXI3 port.

For more information, see [Figure 1-1 Internal memory processing on page 1-13](#).

# Chapter 4

## Working with the Cortex<sup>®</sup>-M3 DesignStart<sup>™</sup> example design

This chapter describes how to work with an example design targeting a low-cost evaluation board, Digilent Arty *Artix 7* (A7). This example design is provided to demonstrate the integration and software development using the Cortex-M3 processor. The example is based on the Digilent Arty A7-35T board, and uses some of the standard Xilinx peripherals to connect to some of the features on the board. The example is intended to show typical usage, rather than a completely minimal Cortex-M3 processor design.

The board provides the Digilent Pmod<sup>™</sup> peripheral module headers for peripherals, and shield expansion headers to support additional expansion. You can use the optional Arm V2C-DAPLink board with these headers to use Cortex-M3 for easy debug and software development. If you do not use the V2C-DAPLink board, you can still connect a *Serial Wire Debug* (SWD) probe (Arm Keil<sup>®</sup> ULINK<sup>™</sup> or similar) to J4 (**nSRST** on I/O[39], **SWDIO** on I/O[40], and **SWCLK** on I/O[41]).

Some features of the example design detect the presence of the V2C-DAPLink board, and adapt accordingly. The V2C-DAPLink board includes pass-through headers for an additional shield board to be connected on top.

The block diagram of the design is available in `/docs/m3_for_arty_a7_example_design.pdf`.

The example design has the following functions:

- UART to output to either the Arty onboard USB connector, or the V2C-DAPLink board, when fitted.
- GPIO\_0 connected to the four DIP switches, SW[3:0], and the four green LEDs LD[7:4].
- GPIO\_1 connected to the four push button switches, BTN[3:0], and the four multicolor LEDs.
- QSPI\_0 connected to the Arty on-board *Quad Serial Port Interface* (QSPI) flash memory.
- BRAM ctrl 0 connected to 64KB of internal FPGA BRAM.

The following peripherals are connected to the V2C-DAPLink adaptor board using J4.

- QSPI 1 connected to the adaptor board QSPI flash memory.
- SPI 0 connected to the adaptor board SD card memory.

A number of pre-built files are provided with the example design. For more information, see [6.3 Example design reference files on page 6-70](#).

---

**Note**

The example design files are modified by the Vivado tool when you open the design, so it might be useful to copy the /hardware directory before working with it. For more information on the directory structure, see [1.2 Directory structure on page 1-12](#).

---

It contains the following sections:

- [4.1 Editing the A7 example design on page 4-36](#).
- [4.2 Debug on page 4-37](#).
- [4.3 Memory map on page 4-38](#).
- [4.4 QSPI multiplexing for the V2C-DAPLink board on page 4-41](#).
- [4.5 Interrupt mapping on page 4-42](#).
- [4.6 Constraints on page 4-43](#).
- [4.7 Loading the pre-built bitstream on page 4-44](#).
- [4.8 Loading the flash file on page 4-45](#).
- [4.9 Bit file regeneration on page 4-47](#).
- [4.10 Simulation on page 4-48](#).

## 4.1 Editing the A7 example design

When loading the Artix *Artix 7* (A7) example design for the first time, if warning messages are issued about either missing IP blocks (Cortex-M3 processor) or board files (Digilent board files), then the design must be closed and the instructions for installation of the IP repository and Digilent board files must be followed. For more information on these installations, see [Chapter 2 Installing the Cortex®-M3 DesignStart™ example design on page 2-14](#). In this scenario, it is possible that Vivado has modified the design file. Therefore, after correct installation of the IP repository and board files is complete, the original design must be installed from the archive.

### Procedure

1. Open Vivado.
2. Select *Open Project* on the splash screen, and select `/hardware/m3_for_arty_a7/m3_for_arty_a7/m3_for_arty_a7.xpr`.
3. In the sources tab, navigate down the hierarchy to the `m3_for_arty_a7_i` instance, marked with a block diagram symbol. Double-clicking this opens the block diagram that is shown in `/docs/m3_for_arty_a7_example_design.pdf`.
4. The design can now be navigated to understand the connectivity and configuration. Double-clicking on any of the IP blocks brings up the configuration for that block.

————— **Note** —————

If you want to change the memory map, this is done in the address editor. However, you must not modify the addresses of the V2C-DAPLink interface peripherals. Additionally, the example hardware memory map matches the pre-compiled software memory map. Therefore, if other peripheral addresses are modified, the equivalent changes must be made in the software.

---

## 4.2 Debug

The example design uses *Serial Wire Debug* (SWD). There is no dedicated Arm debug connector on the Arty *Artix 7* (A7) board, therefore, SWD is only connected to the expansion connector. When the V2C-DAPLink adaptor board is fitted, the SWD ports are connected directly to this board and are accessible through the USB connector as part of the V2C-DAPLink interface.

To use JTAG debug, you must use a suitable debug probe, and route the JTAG connections to the expansion headers.

The example design does not connect to the trace interface. To use trace, you must route the TRACEPORT connections to the expansion headers and use a suitable trace capture device.

### 4.3 Memory map

The following figure shows the memory map of the example Cortex-M3 DesignStart FPGA-Xilinx edition system.

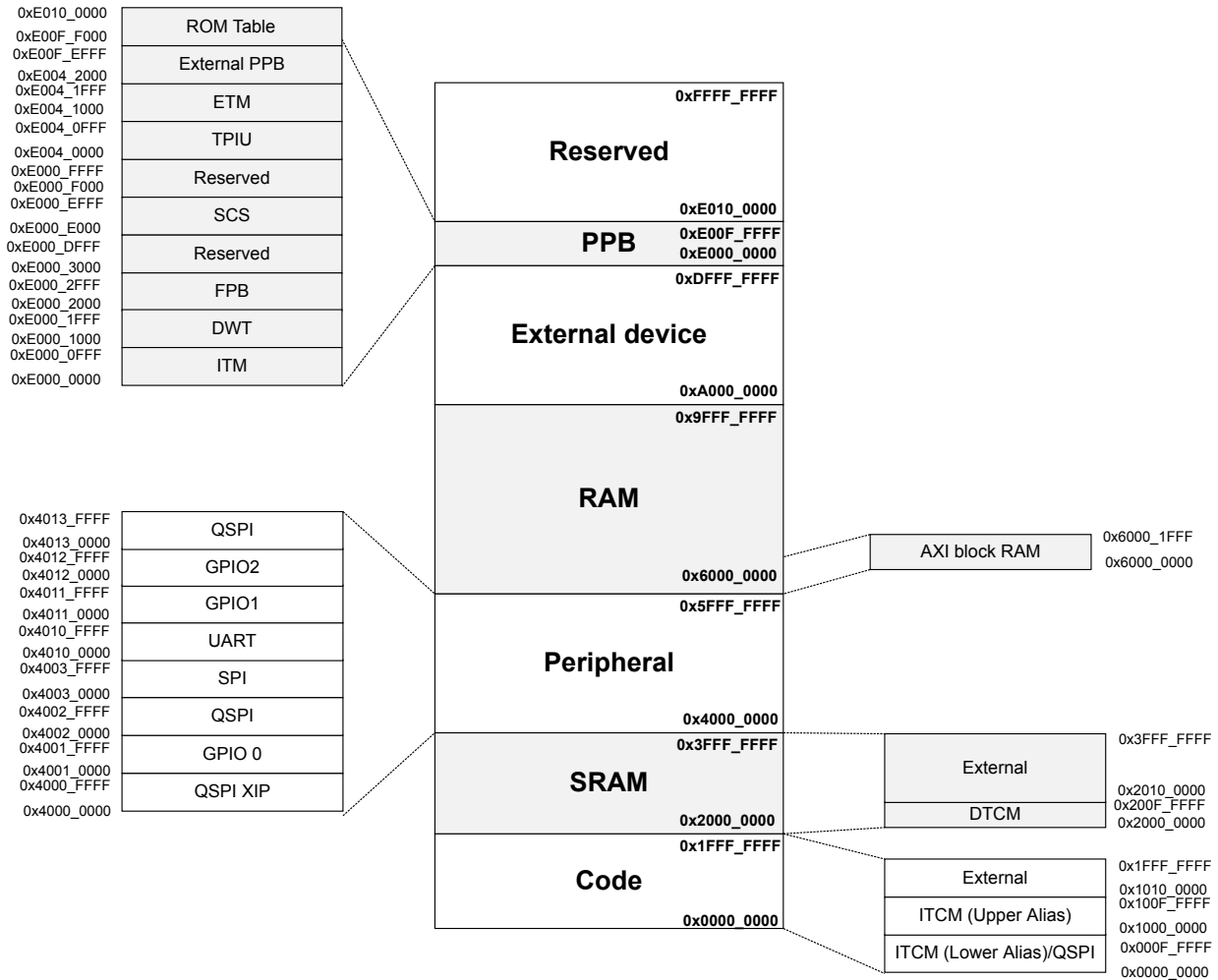

**Figure 4-1 Example system memory map**

The following table shows the example Cortex-M3 DesignStart FPGA-Xilinx edition memory map.

Table 4-1 Example system memory map

Type	Start	End	Peripheral	Instance name	Size	Comment
Code	0x00000000	0x000FFFFF	<i>Instruction Tightly Coupled Memory (ITCM) (lower)</i>	Integrated in the Cortex-M3 processor.	Configurable	Boot region when <b>CFGITCMEN[0]</b> is 1. This indicates that there is no V2C-DAPLink board.
	0x00000000	0x000FFFFF	<i>Quad Serial Peripheral Interface (QSPI)</i>	daplink_if_0/axi_xip_quad_0	1MB	Boot region when <b>CFGITCMEN[0]</b> is 0. This indicates that there is a V2C-DAPLink board. <sup>a</sup>
	0x10000000	0x100FFFFF	ITCM (upper)	Integrated in the Cortex-M3 processor.	1MB	Upper ITCM alias, <b>CFGITCMEN[1]</b> is always HIGH in the example design.
	0x10100000	0x1FFFFFFF	External	-	-	-
SRAM	0x20000000	0x200FFFFF	<i>Data Tightly Coupled Memory (DTCM)</i>	Integrated in the Cortex-M3 processor.	Configurable	<i>eExecute-never (XN)</i> region
	0x20100000	0x3FFFFFFF	External	-	-	-
Peripheral	0x40000000	0x4000FFFF	<i>QSPI eExecute In Place (XIP)</i>	daplink_if_0/axi_xip_quad_0	64KB	Provides code execution from QSPI on the V2C-DAPLink board. <sup>a</sup>
	0x40010000	0x4001FFFF	GPIO 0	daplink_if_0/axi_gpio_0	64KB	Control for QSPI peripheral multiplexer. Bit [0] selects between the two QSPI peripherals. <sup>a</sup>
	0x40020000	0x4002FFFF	QSPI	daplink_if_0/quad_spi_0	64KB	Provides programming control from QSPI on the V2C-DAPLink board. <sup>a</sup>
	0x40030000	0x4003FFFF	SPI	daplink_if_0/axi_single_spi_0	64KB	Single SPI on a dedicated connector.
	0x40040000	0x4004FFFF	Unused	-	-	Unused peripheral region
	0x40100000	0x4010FFFF	UART	axi_uartlite_0	64KB	Baseboard UART or V2C-DAPLink USB, when fitted.
	0x40110000	0x4011FFFF	GPIO 1	axi_gpio_0	64KB	-
	0x40120000	0x4012FFFF	GPIO 2	axi_gpio_1	64KB	-
	0x40130000	0x4013FFFF	QSPI	axi_quad_spi_0	64KB	Provides read/write access to QSPI on V2C-DAPLink board. <sup>a</sup>
0x40140000	0x5FFFFFFF	Unused	-	-	Unused peripheral region.	

<sup>a</sup> The V2C-DAPLink firmware uses this region. Therefore, you must not modify it to retain compatibility with the V2C-DAPLink board.

**Table 4-1 Example system memory map (continued)**

Type	Start	End	Peripheral	Instance name	Size	Comment
RAM	0x60000000	0x60001FFF	BlockRam	axi_bram_ctrl_0	8KB	Additional area of RAM. This also supports code execution. <sup>a</sup>
	0x60002000	0x9FFFFFFF	Unused	-	-	Unused RAM region.
External device	0xA0000000	0xDFFFFFFF	Unused	-	-	Unused external device region.
System	0xE0000000	0xE0000FFF	<i>Instrumentation Trace Macrocell (ITM)</i>	Integrated in the Cortex-M3 processor.	4KB	-
	0xE0001000	0xE0001FFF	<i>Data Watchpoint and Trace (DWT)</i>	Integrated in the Cortex-M3 processor.	4KB	-
	0xE0002000	0xE0002FFF	<i>Flashpatch and Breakpoint (FPB)</i>	Integrated in the Cortex-M3 processor.	4KB	
	0xE0003000	0xE000DFFF	Reserved	-	-	-
	0xE000E000	0xE000EFFF	<i>System Control Space (SCS)</i>	Integrated in the Cortex-M3 processor.	4KB	<i>Nested Vectored Interrupt Controller (NVIC), Debug, and system control registers.</i>
	0xE000F000	0xE003FFFF	Reserved	-	-	-
	0xE0040000	0xE0040FFF	<i>Trace Port Interface Unit (TPIU)</i>	Integrated in the Cortex-M3 processor.	4KB	-
	0xE0041000	0xE0041FFF	<i>Embedded Trace Macrocell (ETM)</i>	Integrated in the Cortex-M3 processor.	4KB	
	0xE0042000	0xE00FEFFF	External PPB	-	-	
	0xE00FF000	0xE0100000	ROM table	Integrated in the Cortex-M3 processor.	4KB	
Reserved	0xE0100000	0xFFFFFFFF	-	-	-	-

All the AXI peripherals that are detailed in the example design are mapped to either of the following:

- Peripheral region (0x40000000 to 0x5FFFFFFF).
- SRAM region (0x60000000 to 0x9FFFFFFF) in the case of the block RAM controller.

If the V2C-DAPLink board is not fitted, then the ITCM RAM, implemented in FPGA memory, is mapped to both 0x00000000 and 0x10000000. Code that is preloaded into the ITCM RAM is executed from address 0x00000000 from boot-up.

If the V2C-DAPLink board is fitted, then the ITCM RAM is only mapped to 0x10000000. For code execution, the V2C-DAPLink board contains a QSPI AXI peripheral configured to *eXecute In Place* (XIP) mode. This peripheral is named `qspi_xip` and is mapped to address 0x00000000. Code is executed from this XIP QSPI device on boot-up.

The DTCM is always mapped starting at 0x20000000. In contrast to other Cortex-M processors, which do not have a TCM, the DTCM is XN.



## 4.4 QSPI multiplexing for the V2C-DAPLink board

The *Quad Serial Port Interface* (QSPI) device, that is fitted to the V2C-DAPLink board, has two Xilinx QSPI AXI controllers. A single GPIO signal from a GPIO peripheral can select one of the two controllers to use. One of the controllers is configured in *eXecute In Place* (XIP) mode, the other controller is configured in normal mode, which is required to write to the memory device.

For more information on the peripherals and their memory map, see [Table 5-1 Interface type on page 5-53](#)

---

**Caution**

If software is intended to be run from the V2C-DAPLink board, then the software must not switch the GPIO signal across to the controller in normal mode. If this happened, then the processor can no longer read the code and the processor enters LOCKUP state.

---

## 4.5 Interrupt mapping

The following table shows the interrupts that the example system uses.

**Table 4-2 Example system interrupts**

Number	Name	Description
0	<b>UART0_IRQn</b>	UART 0 interrupt
1	<b>GPIO0_IRQn</b>	GPIO 0 interrupt
2	<b>GPIO1_IRQn</b>	GPIO 1 interrupt
3	<b>QSPI0_IRQn</b>	<i>Quad Serial Port Interface (QSPI) 0, (Arty board) interrupt</i>
4	<b>DAP_QSPI0_IRQn</b>	V2C-DAPLink board QSPI 0 interrupt
5	<b>DAP_SPI0_IRQn</b>	V2C-DAPLink board SPI 0 interrupt
6	<b>DAP_QSPI_XIP_IRQn</b>	V2C-DAPLink board QSPI <i>eXecute In Place (XIP)</i> interrupt

If you use CMSIS for your software flow, these interrupts are enumerated in the `ARTY_CM3.h` and `startup_ARTY_CM3.s` files.

————— **Note** —————

Additionally, **IRQ[31]** is connected to **DAPLINK\_fitted\_n**. This is used as a level-detect non-interrupt signal to determine if the V2C-DAPLink is fitted.

—————

## 4.6 Constraints

Two constraint files for the example design are included in the `/hardware/m3_for_arty_a7/constraints` folder.

The constraints include internal timing constraints for the Cortex-M3 processor, particularly asynchronous clock domain crossing paths. These constraints must be included in any design that uses the Cortex-M3 processor. The majority of the I/O connections are made using the board file connections, which automatically populate the I/O pad and I/O voltage standard. The exception is the shield connector, which goes to the V2C-DAPLink adaptor board. This uses a tristate port due to the mix of signal direction. Since this does not map directly onto the board file, the I/O pad and I/O standards for the shield connector are defined in the synthesis constraint file.

## 4.7 Loading the pre-built bitstream

The design is provided with a prebuilt bit file in `V:/hardware/m3_for_arty_a7/m3_for_arty_a7/m3_for_arty_a7_reference.bit`. This bit file allows you to program the Arty *Artix 7* (A7) board with the example design, which can be used to demonstrate correct connection, programming, and operation of the Arty A7 board. This file loads the volatile memory in FPGA RAM. Therefore, the FPGA programming is only valid while the board is powered on. Additionally, if Prog is pressed, then the flash program image is loaded into the FPGA, overwriting any existing FPGA image.

### Caution

If you have not programmed the flash, then the Digilent example design is the image in the flash, and this is loaded into the FPGA. In this instance, the board is not running a Cortex-M processor.

In these instructions, `V:` is used to refer to the package install directory.

The bitstream includes a software image that is preloaded into *Instruction Tightly Coupled Memory* (ITCM).

To load the pre-built bitstream:

### Procedure

1. Open Vivado.
2. On the splash screen, from Flow → Hardware manager, select `V:/hardware/m3_for_arty_a7/m3_for_arty_a7/m3_for_arty_a7.xpr`.
3. Connect the Arty board using the micro-USB connection, not the V2C-DAPLink connector.
4. Connect a terminal application (for example, TeraTerm) to the USB UART port. This is automatically created when Arty A7 board is connected.
5. Set the terminal to: Baud rate 115,200 8 bits One stop No parity .
6. Open the hardware manager, and select *Open Target*.
7. Right click on the Digilent A7 board's *xc7A35t* device.
8. Select *Program Device* and locate the `m3_for_arty_a7_reference.bit` bitstream file.
9. Wait while the bitstream is downloaded.
10. If Reset is pressed on the Arty A7 board, the following message appears on the splash screen and displayed on the terminal.

```
*****  
Arm Cortex-M3 Revision 1 Variant 2  
Example design for Digilent A7 board  
V2C-DAPLink board not detected  
Use DIP switches and push buttons to control LEDS  
Version 1.0  
*****  
Bram readback correct  
Base SPI readback correct
```

11. Test the operation of the LEDs using the DIP switches and the push buttons.

If PROG is pressed on the Arty A7 board, then the built-in Digilent reference design is loaded. This displays a different splash screen on the terminal, using the same UART board rates. This reference design has different functions for the DIP and push button switches. To return to the Arm reference design, you must reprogram the board using the instructions in this section. To make the Arm reference design persistent, follow the steps in [4.8 Loading the flash file on page 4-45](#) to load the design in flash.

## 4.8 Loading the flash file

A flash file is provided that you can use to program the Arty board with the example design and a simple test program. This flash file can be used to demonstrate correct connection, programming, and operation of the Arty *Artix 7* (A7) board. The non-volatile flash image is used to load the FPGA on board powerup, and also when Prog is pressed.

————— **Note** —————

The board is provided with a Digilent example design. Programming the flash overwrites this design.

In these instructions, *V:* is used to refer to the package install directory.

The flash file includes a software image that is preloaded into *Instruction Tightly Coupled Memory* (ITCM).

To load the pre-built flash file:

### Procedure

1. Open Vivado.
2. On the splash screen, select *Open Project*, and select *V:/hardware/m3\_for\_arty\_a7/m3\_for\_arty\_a7/m3\_for\_arty\_a7.xpr*.
3. Connect the Arty board using the micro-USB connection, not the V2C-DAPLink connector.
4. Connect a terminal application (for example, TeraTerm) to the USB UART port. This is automatically created when Arty A7 board is connected.
5. Set the terminal to: Baud rate 115,200 8 bits One stop No parity .
6. Open the Hardware manager, and select *Open Target*. Select *Auto Connect*.
7. Right-click on the Digilent A7 board's *xc7A35t*, and select *Add configuration memory device*.
8. Select *mt25q1128-spi-x1\_x2\_x4*. Select OK. The following figure shows the resultant hardware tab in Vivado.

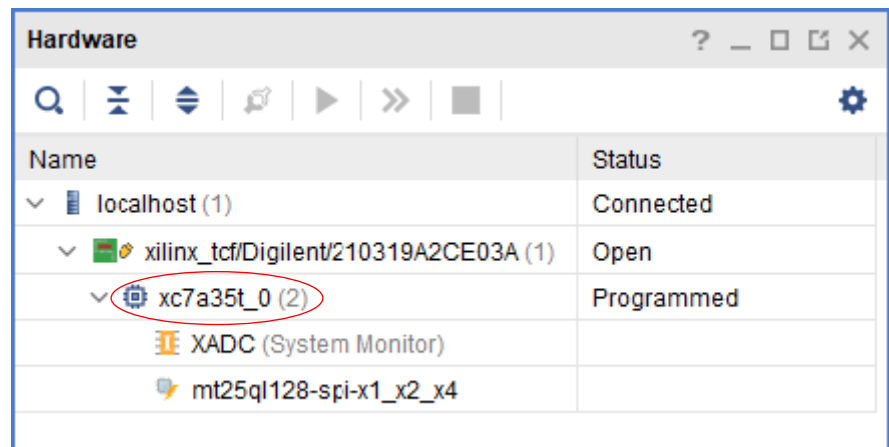

**Figure 4-2 Arty A7 board hardware tab in Vivado**

9. In the *Do you want to program the configuration device now* prompt, click OK.
10. Select *V:/hardware/m3\_for\_arty\_a7/m3\_for\_arty\_a7/m3\_for\_arty\_a7\_reference.mcs* for the configuration file.

11. Click OK to program the flash.

When the flash is programmed, press Prog to load the FPGA with the example design.

## 4.9 Bit file regeneration

You can regenerate the bit file using *Run Implementation* and *Generate Bitstream*. Any new bitstream is located in the Vivado numbered implementation directory, for example, m3\_for\_arty\_a7/m3\_for\_arty\_a7.runs/impl\_1/.

## 4.10 Simulation

A testbench is provided which instantiates the example design. The testbench allows for simulation with both the V2C-DAPLink board fitted and not fitted. This is controlled with a Verilog define in /testbench/tb\_m3\_for\_arty.v. Additionally, the testbench allows simulation of the V2C-DAPLink peripherals that are present, but with the V2C-DAPLink fitted link removed. This configuration allows faster simulation because the code is executed from the *Instruction Tightly Coupled Memory* (ITCM) instead of the V2C-DAPLink *Quad Serial Port Interface* (QSPI) flash device model. The testbench stimulates the pushbutton and DIP switches fitted to the host board. It also has a behavioral UART receiver to display the output of the UART onto the simulation console.

To run simulations from Vivado, the Vivado simulator or a third-party simulator has to be installed.

This is selected under Tools → Settings → Simulation → Target Simulator.

The Cortex-M3 IP encryption supports the in-built Vivado simulator and the Questa Advanced simulator. If you already have the Questa Advanced simulator installed in the path, then no other settings are required. However, if the Questa Advanced simulator is not on your path, then the path can be set within Vivado.

This is selected under Tools → Settings → 3rd Party Simulators.

### 4.10.1 Testbench conditionals

The testbench conditional compilation options are controlled by defines at the top of tb\_m3\_for\_arty\_a7.v.

**Table 4-3 Conditional compilation options**

Option name	Description
<code>`INCLUDE_QSPI_MODEL</code>	Set this option if the <i>Quad Serial Port Interface</i> (QSPI) Verilog models have been installed.
<code>`INCLUDE_DAPLINK</code>	Set this option to enable inclusion of the V2C-DAPLink peripherals. Supports lower external stimulus, longer resets, and drivers for <i>Serial Wire Debug</i> (SWD).
<code>`DAPLINK_LINK_NF</code>	If <code>`INCLUDE_DAPLINK</code> option is set, code is normally executed from the V2C-DAPLink QSPI model, and UART output directed to the V2C-DAPLink UART ports. If <code>`DAPLINK_LINK_NF</code> is also set, then code is executed from <i>Instruction Tightly Coupled Memory</i> (ITCM) and UART outputs are directed to the base board UART ports.

### 4.10.2 Executing code from QSPI

The *Quad Serial Port Interface* (QSPI) on the V2C-DAPLink is configured as an *eExecute-In-Place* (XIP) controller. Within the testbench, the V2C-DAPLink QSPI device model, S25fl128S, is preloaded with code from the qspi-a7.hex file. If ``INCLUDE_DAPLINK` is defined, and ``DAPLINK_LINK_NF` is not defined, then code is executed from the QSPI model.

————— **Note** —————

Code execution from the QSPI model is approximately ten times slower than the execution from the *Instruction Tightly Coupled Memory* (ITCM) RAM. This is because of the access of the QSPI and the subsequent data transfer through the AXI interconnect.

### 4.10.3 Wave files

By default, when Vivado activates the simulator window, it only shows the top-level signals. For QuestaSim, two preconfigured wave files are included, wave\_daplink.do and wave\_no\_daplink.do. For the Vivado default simulator, wave\_daplink.wcfg is provided.



# Chapter 5

## V2C-DAPLink board

The optional V2C-DAPLink adaptor board provides a debug flow that is familiar to anyone who is used to working with Cortex-M microcontrollers. It allows Arty FPGA boards to be used with mbed OS 2 Classic. This chapter describes the optional V2C-DAPLink adaptor board and how it is used.

It contains the following sections:

- [5.1 V2C-DAPLink adaptor board features](#) on page 5-50.
- [5.2 V2C-DAPLink configuration](#) on page 5-52.
- [5.3 Flash download requirements](#) on page 5-53.
- [5.4 V2C-DAPLink board layout](#) on page 5-54.
- [5.5 Conditions to enable the DAP interface](#) on page 5-56.
- [5.6 DAP drivers](#) on page 5-57.
- [5.7 Programming the V2C-DAPLink QSPI using drag and drop](#) on page 5-58.
- [5.8 Using the  \$\mu\$ Vision debugger to communicate through V2C-DAPLink](#) on page 5-60.
- [5.9 Using the  \$\mu\$ Vision debugger to download projects through the flash programming utility](#) on page 5-62.
- [5.10 Recovering the DAP connection](#) on page 5-65.

## 5.1 V2C-DAPLink adaptor board features

The board supports the following features:

- Allows Arty *Artix 7* (A7) and *Spartan-7* (S7) FPGA boards to be used with mbed OS 2 Classic.
- V2C-DAPLink *Serial Wire Debug* (SWD) over USB.
- UART over USB.
- Dedicated *Quad Serial Port Interface* (QSPI) flash for code image.
- Micro-SD card for application use (SPI mode only).
- Allows stacking of standard Shield expansion boards.
- DAPLink USB Composite Device:
  - USB *Mass Storage Device Class* (MSC) for programming software images to block RAM and QSPI.
  - USB *Communication Device Class* (CDC) for UART debug with **nSRST** support.
  - USB *Human Interface Device* (HID) for CMSIS-DAP software debug.

The following figure shows the V2C-DAPLink adaptor board, the Arty header breakout pins, and the point where they are interfaced together (this is depicted in orange).

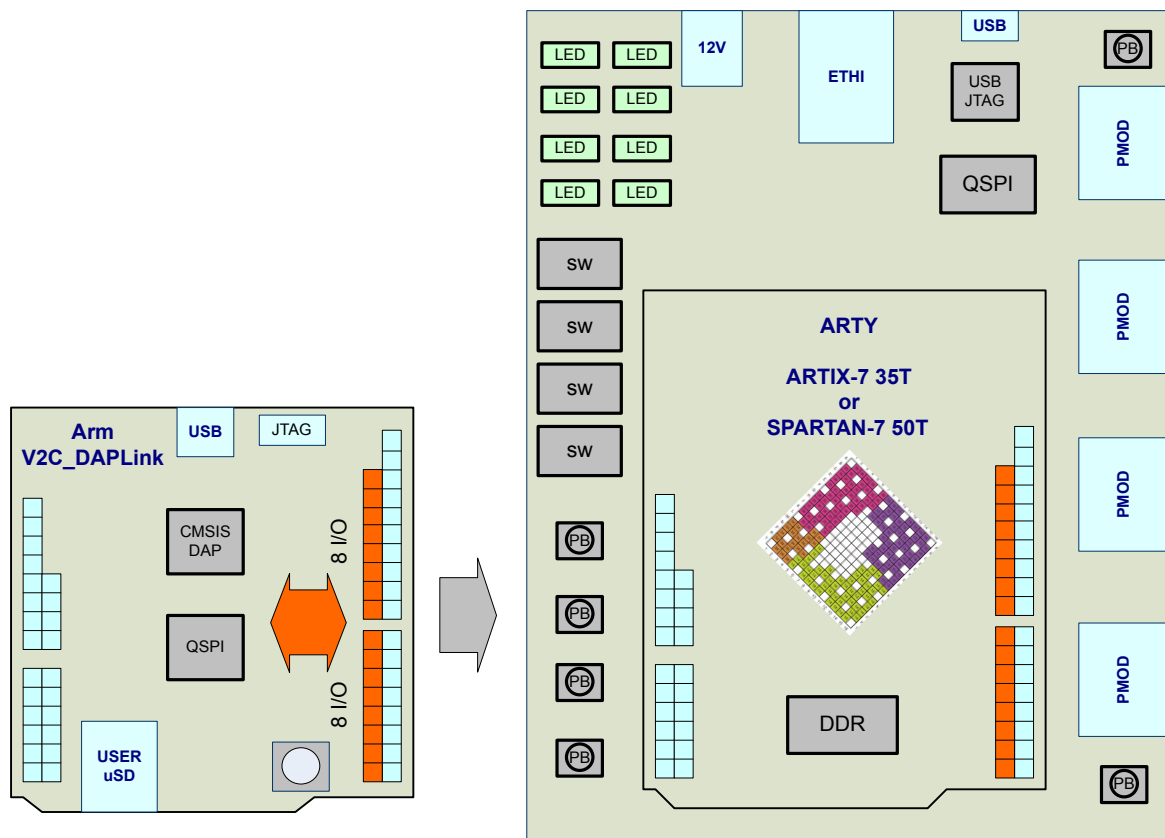

Figure 5-1 V2C-DAPLink adaptor board

A dedicated microcontroller on the V2C-DAPLink board provides the interface between a micro-USB connector and the UART and *Serial Wire Debug* (SWD) interfaces. This is pre-loaded with firmware that is configured to permit drag-and-drop software download onto the on-board QSPI. Using this programming interface requires that the Xilinx QSPI controllers are implemented as shown in the example design (at the same memory locations). The flash programming routine is loaded into target RAM at address  $0x10000000$ , which is the *Instruction Tightly Coupled Memory* (ITCM) upper alias. The

V2C-DAPLink firmware is not intended to work with any processor except a single Cortex-M3 instance as demonstrated in the example design. For more information on the flash programming routine and download requirements, see [5.3 Flash download requirements on page 5-53](#).

The V2C-DAPLink board has a reset switch for the Cortex-M3 processor, **CS\_nSRST**, this reset is also driven from the V2C-DAPLink chip. **CS\_nSRST** must be used to reset the processor **nSYSRESET** and peripherals, but not the processor **DBGRESETn** or the *Debug Access Port* (DAP) resets.

## 5.2 V2C-DAPLink configuration

The V2C-DAPLink board has a configuration jumper, J2. This is used to drive a detect signal to the example design, and has the following effects when used with the example design.

### Jumper open

The processor boots from the *Instruction Tightly Coupled Memory* (ITCM) lower alias. The ITCM initialization is performed as part of FPGA programming on powerup. A debugger sees the ITCM at both `0x00000000` and `0x10000000`. The QSPI on the V2C-DAPLink can be written or accessed using the normal mode peripheral at `0x40020000`. The UART connection to the V2C-DAPLink is unused in this configuration.

### Jumper closed

The processor boots from *Quad Serial Peripheral Interface* (QSPI) *eXecute In Place* (XIP). The upper ITCM alias at `0x10000000` is still initialized at FPGA powerup, but is available for application use. Breakpoints cannot be placed directly in the QSPI image. There is no built-in process to copy any code from the QSPI XIP region into ITCM.

The UART connection to the V2C-DAPLink is connected to the example design UART in this configuration.

————— **Note** —————

For more information on the memory map, see [4.3 Memory map on page 4-38](#).

—————

### 5.3 Flash download requirements

The DAPLink processor on the V2C-DAPLink is pre-programmed with a flash download routine. This is used for drag-and-drop programming and debugger code download. To maintain compatibility with the pre-programmed image, you must retain the following components in your system.

**Table 5-1 Interface type**

Base address	Interface path in example design	Description
0x00000000	Daplink_if_0/ axi_xip_quad_spi_0/AXI_FULL	Code execution from dedicated <i>Quad Serial Port Interface</i> (QSPI) on V2C-DAPLink memory interface.
0x40000000	Daplink_if_0/ axi_xip_quad_spi_0/AXI_LITE	Configuration interface that is used to set QSPI clock polarity and clock phase for <i>eXecute-In-Place</i> (XIP) execution.
0x40020000	daplink_if_0/axi_quad_spi_0	Normal mode QSPI controller used to read, write, and verify code to the dedicated QSPI on the V2C-DAPLink memory interface.
0x40010000	Daplink_if_0/axi_gpio_0	Bit [0] is used to control muxing of the QSPI interface.  <b>0</b> QSPI XIP mode. QSPI is read-only through the <b>axi_xip_quad_spi_0</b> . This is the setting for executing code from the V2C-DAPLink. This is default option.  <b>1</b> QSPI read, write, and verify through the normal mode <b>axi_quad_spi_0</b> controller.

————— **Note** —————

There is another peripheral, **axi\_single\_spi\_0** on the V2C-DAPLink board. This is a normal mode SPI controller that is used to write to the V2C-DAPLink SD card slot. In the example design, this has a base address of 0x40030000. The address of this peripheral is not fixed, however, Arm recommends that you do not change the address unless required.

————— **Caution** —————

Bit [0] of **axi\_gpio\_0** must be held LOW while V2C-DAPLink code is executing. If your code must be run from V2C-DAPLink, then you must ensure that your code does not set this signal HIGH.

## 5.4 V2C-DAPLink board layout

The V2C-DAPLink adaptor board layout is based on the Arduino Shield form factor.

The following figure shows the board layout.

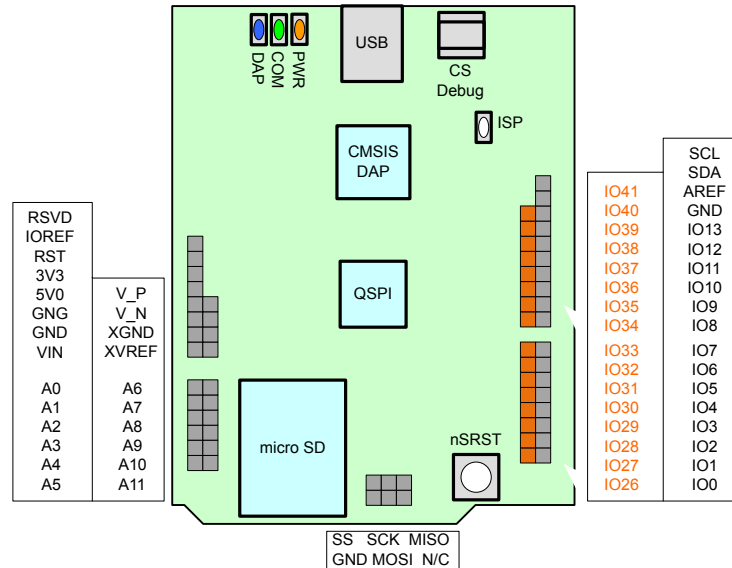

**Figure 5-2 V2C-DAPLink board layout**

The optional V2C-DAPLink board features are supported on the inner row expansion pins. The shield adaptor pins pass through to a shield board above the optional V2C-DAPLink board.

The following table shows the Shield I/O pin mapping.

**Table 5-2 Shield I/O mapping**

I/O pin	Artix 7 bank	SPARTAN-7 bank	V2C-DAPLink signal
26	14	14	SD_nSS
27	14	14	SD_MISO
28	14	14	SD_MOSI
29	14	14	SD_SCLK
30	14	14	QSPI_Q0
31	14	14	QSPI_Q1
32	14	14	QSPI_Q2
33	14	14	QSPI_Q3
34	CONFIG	14	RSVD (V2C-DAPLink fitted)
35	14	14	QSPI_CLK
36	14	14	QSPI_nS

**Table 5-2 Shield I/O mapping (continued)**

<b>I/O pin</b>	<b>Artix 7 bank</b>	<b>SPARTAN-7 bank</b>	<b>V2C-DAPLink signal</b>
37	14	CONFIG	<b>UART_RX</b>
38	14	CONFIG	<b>UART_TX</b>
39	14	CONFIG	<b>CS_nSRST</b>
40	14	14	<b>CS_DIO</b>
41	14	14	<b>CS_CLK</b>

## 5.5 Conditions to enable the DAP interface

The V2C-DAPLink board provides a USB interface to the Cortex-M3 design *Serial Wire Debug* (SWD) connections.

For the V2C-DAPLink board to work, the implementation in the Arty *Artix 7* (A7) board must contain a Cortex-M3 processor supporting SWD with the *Quad Serial Port Interface* (QSPI) flash interfaces present. For more information on memory map configuration, see [Chapter 4 Working with the Cortex®-M3 DesignStart™ example design on page 4-34](#).

The Cortex-M3 processor is an integral part to program QSPI using the *Debug Access Port* (DAP). To debug or program using the DAP, the processor must be in a valid state of execution. Corrupt software can cause the system to lock. If this happens, you might need to perform a recovery procedure. For more information, see [5.10 Recovering the DAP connection on page 5-65](#).



## 5.6 DAP drivers

The *Debug Access Port* (DAP) device issues USB codes for many devices to the host PC.

- Mbed VFS USB drive (Microsoft drivers).
- USB Serial Device (Mbed or Microsoft drivers).
- DAP interface.

### Useful references

- <https://os.mbed.com/handbook/Windows-serial-configuration>
- <https://os.mbed.com/handbook/CMSIS-DAP>.
- <https://os.mbed.com/handbook/DAPLink>.
- <https://os.mbed.com/docs/v5.9/tools/daplink.html>.

## 5.7 Programming the V2C-DAPLink QSPI using drag and drop

To program the V2C-DAPLink *Quad Serial Port Interface* (QSPI) using the drag and drop mechanism:

### Procedure

1. Configure the Arty *Artix 7* (A7) board with a valid Cortex-M3 processor design. Program the Arty A7 board with the reference MCS flash file. For more information on loading the flash file, see [4.8 Loading the flash file on page 4-45](#). This is required for step 6 in this procedure which causes a suitable image to be loaded into the FPGA which supports V2C-DAPLink.
2. Connect the V2C-DAPLink board to the Arty A7 board headers.
3. You must ensure that the V2C-DAPLink jumper is connected to J2, *Cfg*.
4. You must power the Arty A7 board by connecting the USB to the host.
5. You must power the V2C-DAPLink board by connecting the USB to the host.
  - a. You can now connect a UART terminal program to both USB serial ports that the base Arty board and V2C-DAPLink board create. Both UARTs have settings of Baud rate 115,200 8 bits One stop No parity . With the J2 CFG jumper fitted, the terminal output from the FPGA is directed to the V2C-DAPLink UART. With J2 removed, the output is directed to the Arty board UART.
6. Press PROG on the Arty A7 board to ensure that it has configured the FPGA.
7. Press nRST on the V2C-DAPLink board to perform a clean reboot of the software that is programmed to the V2C-DAPLink QSPI device. The V2C-DAPLink might be programmed with a Cortex-M -compatible software image, however, this might not match the hardware design which you are using.
8. The host displays a file window similar to the following figure:

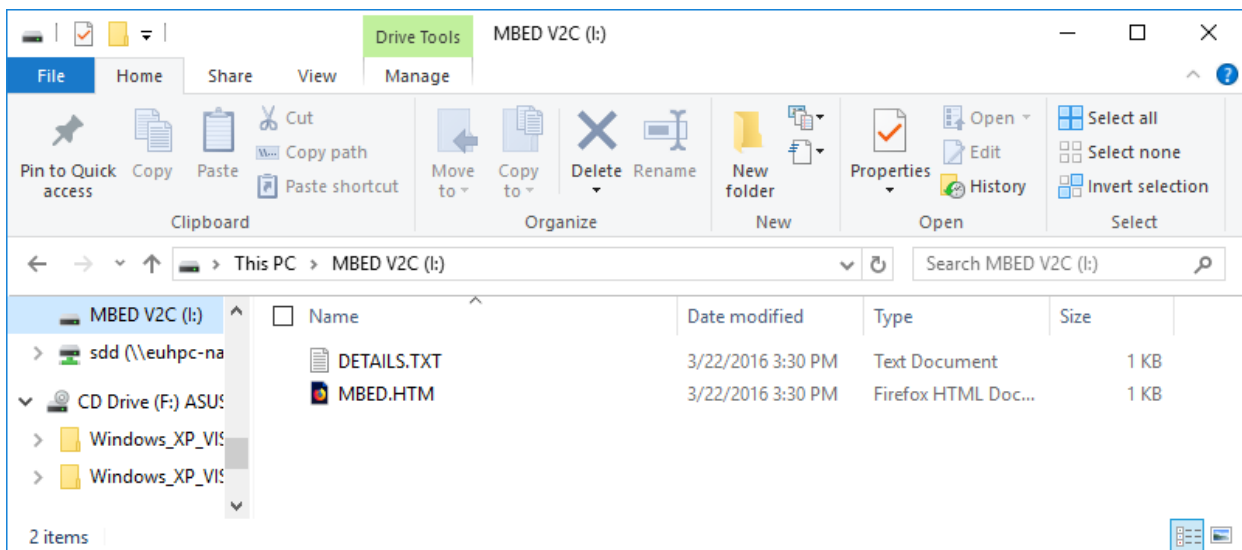

**Figure 5-3 File window**

9. The V2C-DAPLink QSPI can be programmed with the `qspi_a7.bin` file generated as part of the software compilation flow. For more information, see [6.5.1 Software design post processing on page 6-77](#). This `.bin` file is automatically produced when the software is compiled and it is located in `/software/m3_for_arty_a7/Build_keil/qspi_a7.bin`.
10. Drag and drop `qspi_a7.bin` onto `This PC\MBED V2C`.

The drive for `This PC\MBED V2C` disappears, the V2C-DAPLink QSPI is programmed, and the drive reappears. If there are any errors, they are reported in a text file, `Fail.txt`. After the drag and drop file

transfer has completed, the new software runs when the processor is reset. For example, when the nRST button on the V2C-DAPLink board is pressed.

## 5.8 Using the $\mu$ Vision debugger to communicate through V2C-DAPLink

To set up a  $\mu$ Vision project to communicate through V2C-DAPLink:

### Procedure

1. Load the project and then go to *Options for Target <name of executable>* (alt+F7).
2. Select the Debug tab.
3. On the right-hand side of the screen deselect *Load Application at Startup*.
4. Select *Use:*, and then select *CMSIS-DAP Debugger* from the drop-down menu.

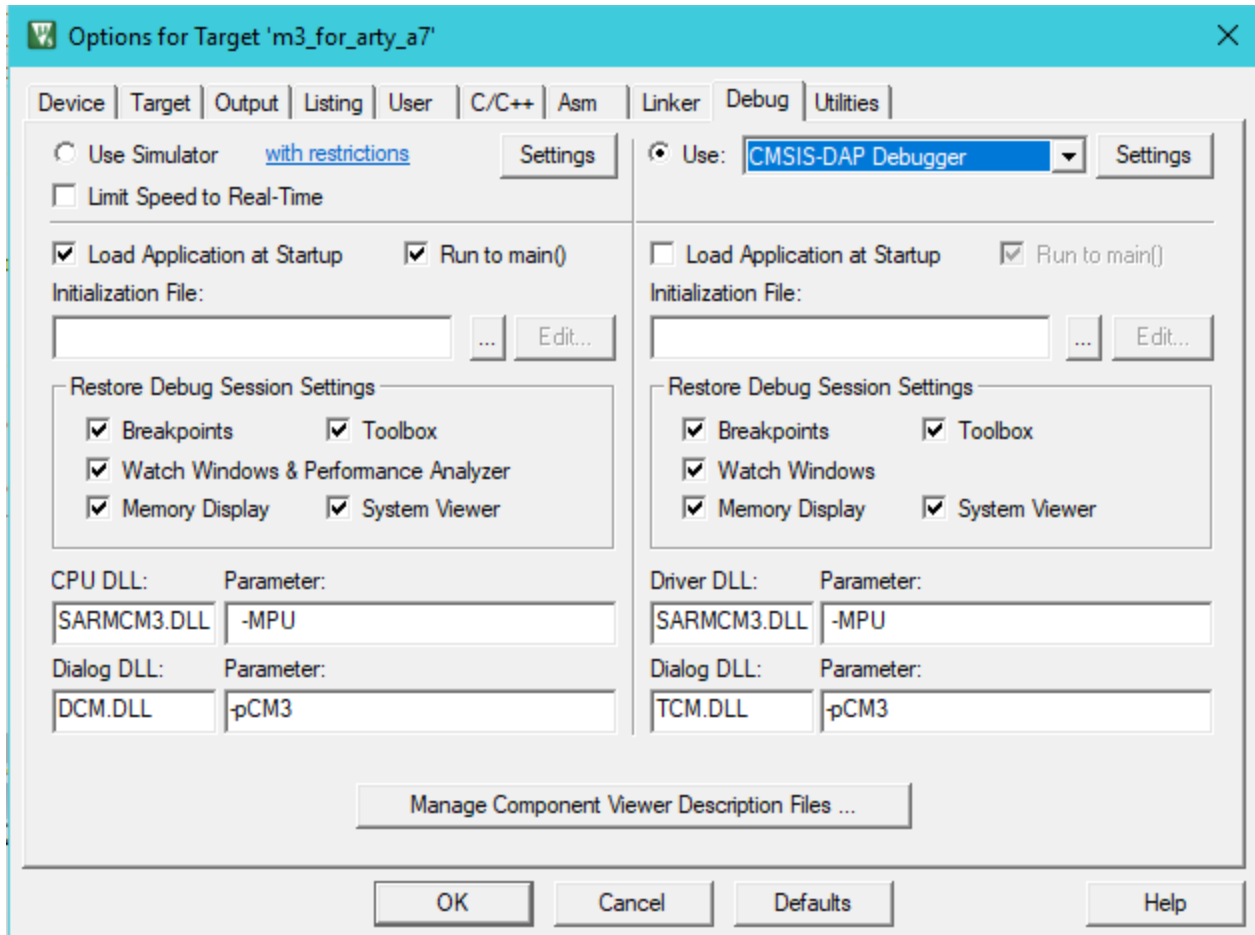

Figure 5-4 Debug tab

5. Click Settings and select the subsequent Debug tab.

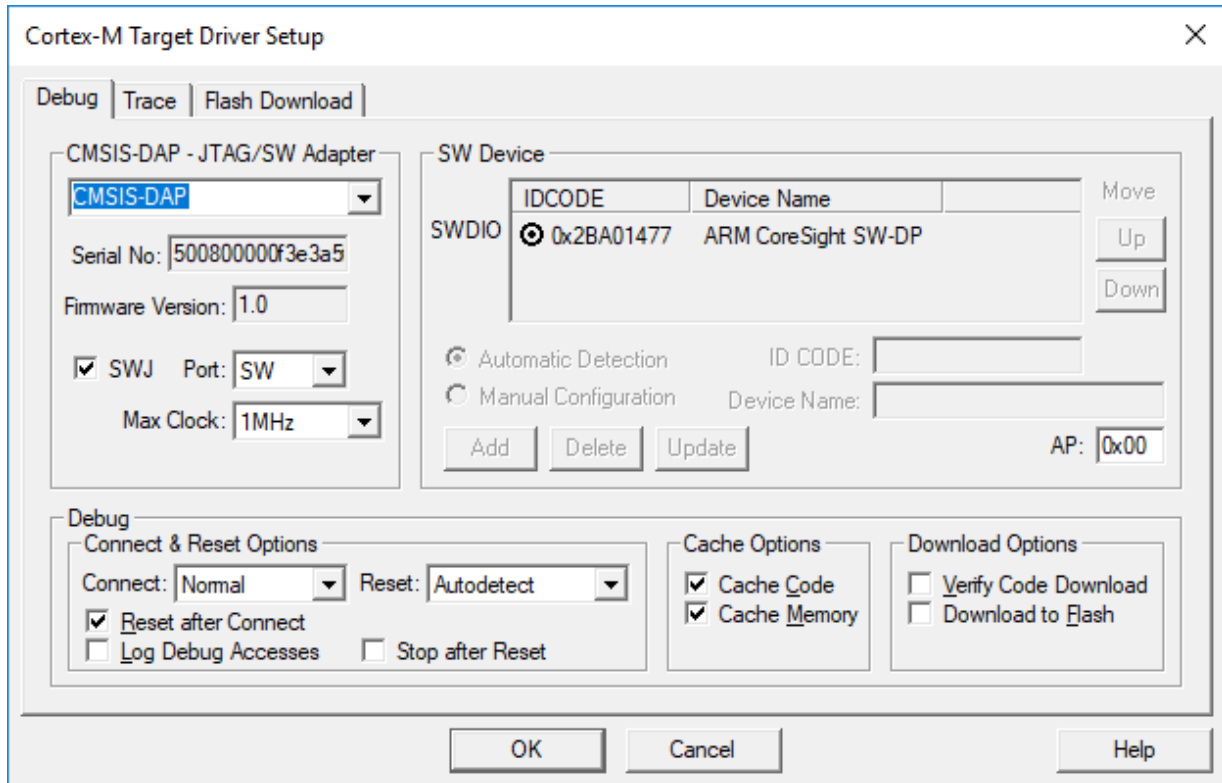

Figure 5-5 Debug tab

6. Ensure that *SWJ* is ticked and select *CMSIS-DAP* from the drop-down menu. The *IDCODE* must read a valid value and the device name must indicate *ARM Core Sight SW-DP*.
7. Click OK in the *Cortex-M Target Driver Setup* and *Options for Target <name of executable>* screens.
8. You can now connect the debugger to the target by clicking on the debug icon.



Figure 5-6 Debug icon

## 5.9 Using the $\mu$ Vision debugger to download projects through the flash programming utility

To set up a  $\mu$ Vision project to download projects through the flash programming utility, you must have the correct driver installed.

The file S25FL128S\_V2C.FLM must first be copied to C:\Keil\_v5\ARM\Flash, or wherever your Keil installation is. This file can be found in the V:\software\flash\_downloader directory.

### Procedure

1. Load the project and then go to *Options for Target <name of executable>* (alt+F7)
2. Select the Debug tab.
3. Click on Settings and select the subsequent Flash Download tab

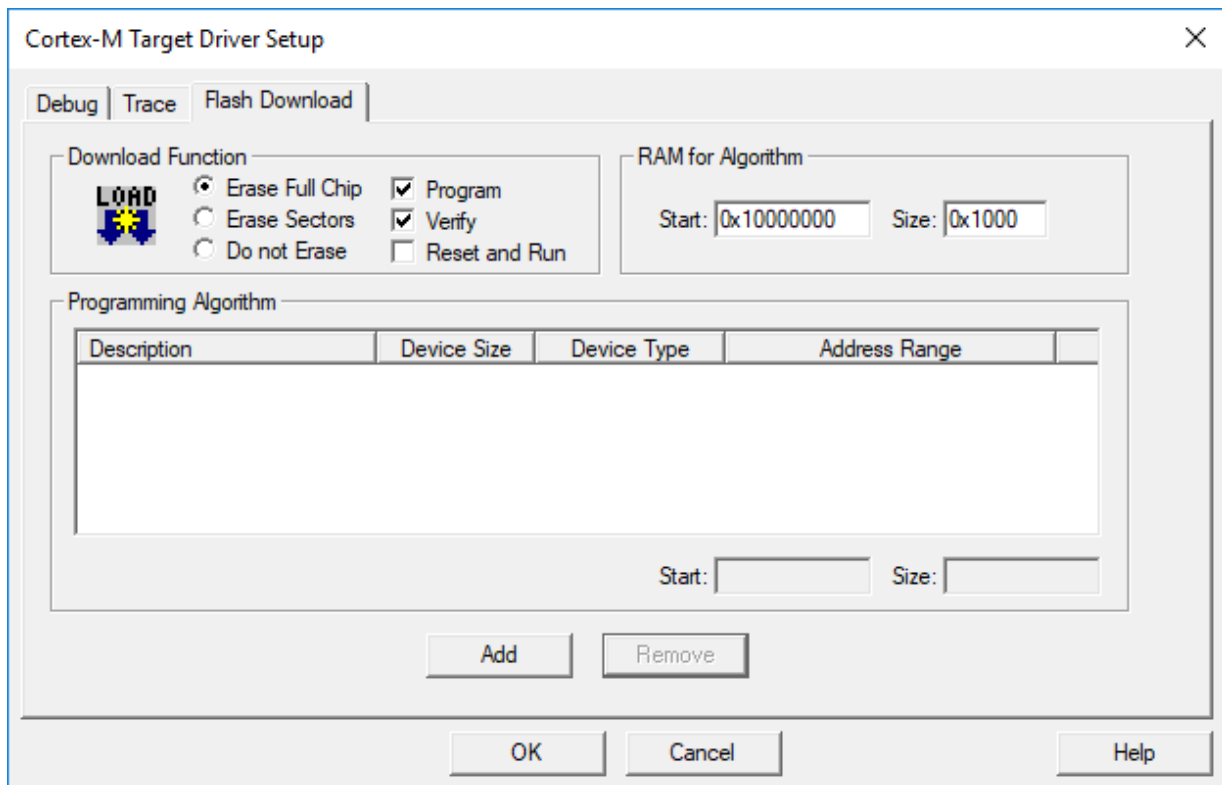
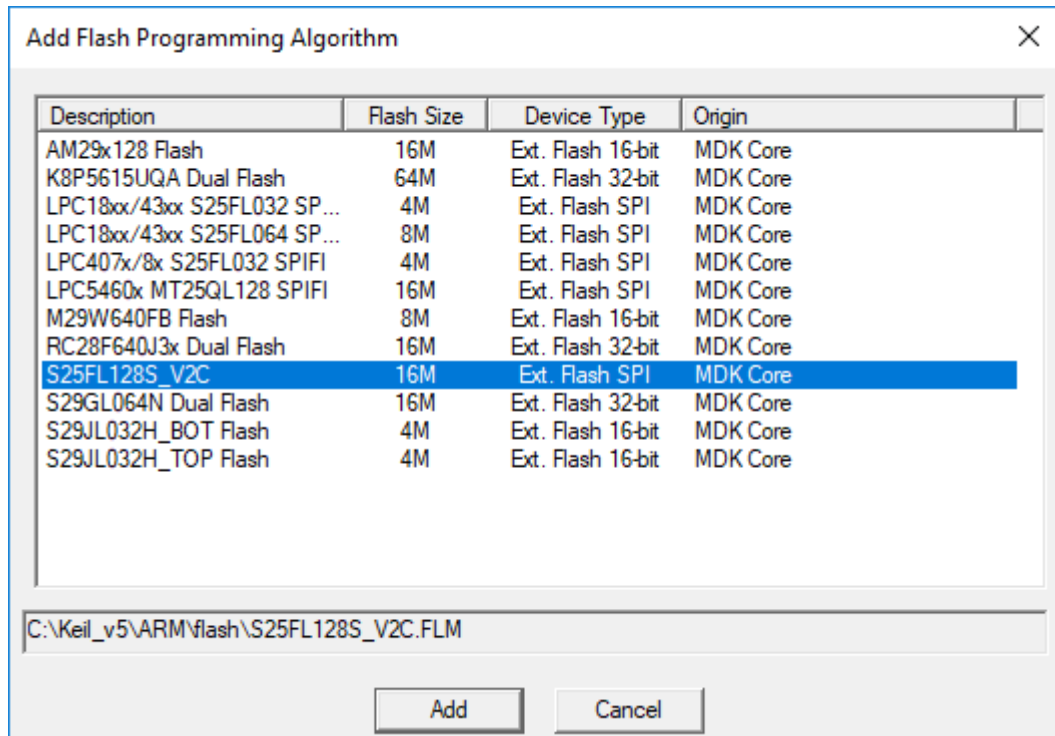

Figure 5-7 Flash Download tab

4. Click Add and select the driver file S25FL128S\_V2C.



**Figure 5-8 Add Flash Programming Algorithm**

5. Click Add and check that the *Start* and *Size* text boxes are filled with `0x10000000` and `0x1000` respectively.
6. Click OK.
7. Select the Utilities tab from the *Options for Target <name of executable>* window and select *Use Target Driver for Flash Programming* and tick *Use Debug Driver*.

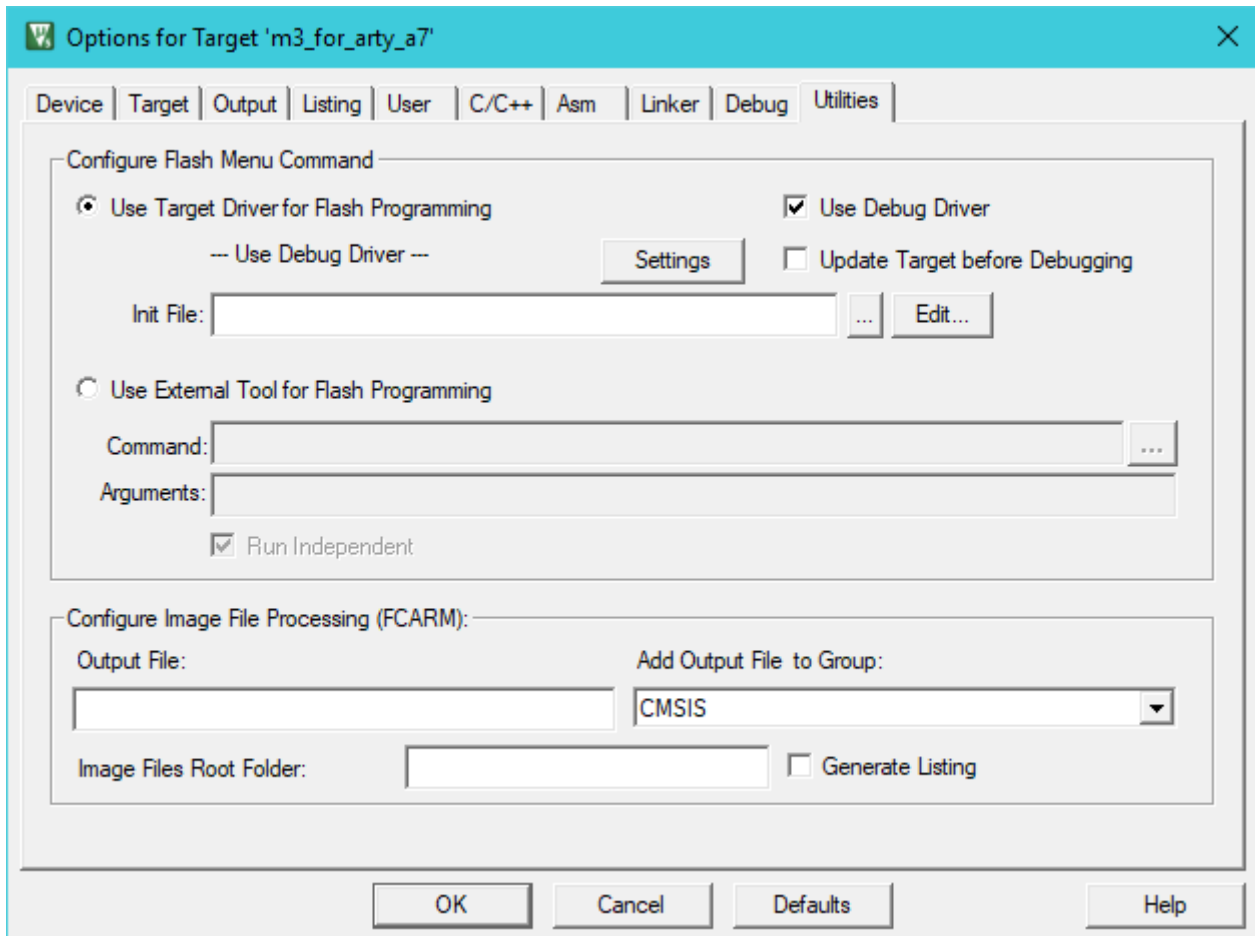

Figure 5-9 Utilities tab

8. Click OK.
9. Click on the download icon to download flash.



Figure 5-10 Download flash icon



## 5.10 Recovering the DAP connection

If you program the *Quad Serial Port Interface* (QSPI) with software that causes the processor to lock up, the QSPI might become inaccessible. To recover the *Debug Access Port* (DAP) connection, a valid image must be programmed into the V2C-DAPLink QSPI or the device must be erased.

### Procedure

1. Configure the Arty *Artix 7* (A7) board with a valid Cortex-M3 processor design.
2. Connect the V2C-DAPLink to the Arty boards headers.
3. Ensure the V2C-DAPLink jumper is removed from J2, *Cfg*.
4. Connect the USB to the host to power:
  - The Arty board.
  - The V2C-DAPLink board.
5. Press PROG on the Arty board to ensure it has configured the FPGA.
6. Connect to the DAP with the  $\mu$ Vision debugger.
7. Load the project and then go to the *Options for Target <name of executable>* (alt-F7).
8. Select the Debug tab.
9. Click on Settings and go to the Flash Download tab.
10. Ensure *Program* and *Verify* are unticked.

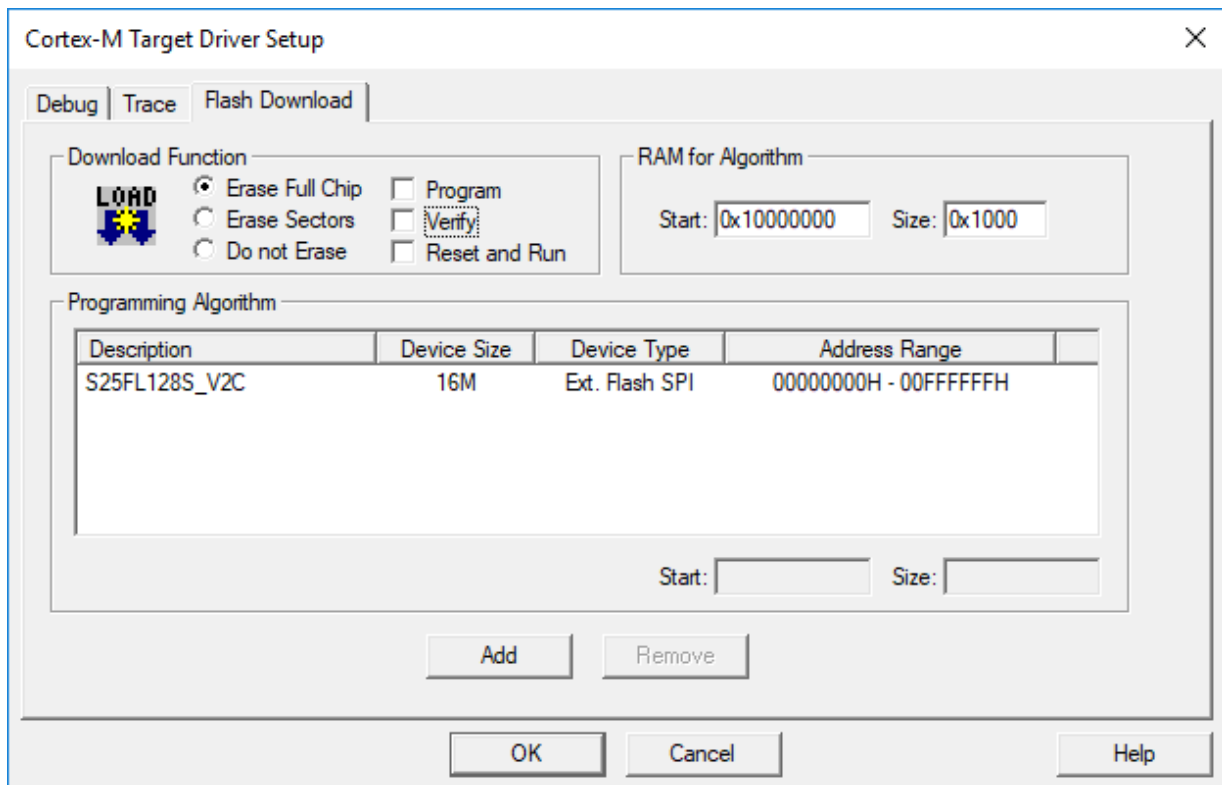

**Figure 5-11** Flash Download tab

11. Click OK in the *Cortex-M Target Driver Setup* and *Options for Target <name of executable>* screens.
12. Click the download icon to erase the device.



**Figure 5-12 Download flash icon**

13. Replace the J2, *Cfg* link on the V2C-DAPLink and press nRST.

# Chapter 6

## Example software design

This chapter describes an example software design, and describes how to build and debug it.

Software for the Cortex-M3 processor can be run either from the *Instruction Tightly Coupled Memory* (ITCM), initialized as part of the FPGA image, or from an external AXI memory.

It contains the following sections:

- [6.1 Example software design for Arty A7 on page 6-68.](#)
- [6.2 Example software design directory structure on page 6-69.](#)
- [6.3 Example design reference files on page 6-70.](#)
- [6.4 Generating the Arty A7 board support package on page 6-71.](#)
- [6.5 Building the example software design on page 6-77.](#)
- [6.6 Software update flow on page 6-78.](#)

## 6.1 Example software design for Arty A7

An example software design is provided which demonstrates the basic functionality of the processor and some peripherals.

The example design software design is compiled using Arm  $\mu$ Vision *Microcontroller Development Kit* (MDK) 5.24 onwards. A project file for the example design is in `V:/software/m3_for_arty_a7/Build_Keil/m3_for_arty_a7.uvprojx`. The example software design uses compiler options for the Cortex-M0 processor. This is the correct choice if your toolchain does not provide explicit support for the Cortex-M3 processor.

The software demonstrates:

- UART output to either the Arty onboard USB connector or the V2C-DAPLink board when fitted.
- GPIO\_0, the LEDs mirror the state of the DIP switches. When each switch is turned on, the appropriate LED is lit.
- GPIO\_1, as each pushbutton is pressed, the appropriate LED rotates around eight possible colors (seven lit states and a single off state).
- QSPI\_0, read and write accesses are testing during powerup.
- BRAM ctrl 0, read and write memory accesses are tested during powerup.

The peripherals on the V2C-DAPLink board are not covered by the software tests.

The example software design relies on the Xilinx *Board Support Package* (BSP) for the example design. You must generate the BSP before you build the software design.

## 6.2 Example software design directory structure

The software structure provided uses the Xilinx software framework for the AXI peripherals and combines this with Arm CMSIS software for the Cortex-M3 processor.

```
<installation_directory>
|_software/
|   |_m3_for_arty_a7/
|       |_Build_Keil/
|           |_cmsis/
|               |_gpio/
|                   |_main/
|                       |_spi/
|                           |_uart/
|                               |_sdk_workspace/
```

The following table describes the directory structure.

**Table 6-1 Directory structure**

File	Description
software/m3_for_arty_a7/Build_Keil/	Build directory.
software/m3_for_arty_a7/cmsis/	Cortex-M3 CMSIS included files and bootfiles.
software/m3_for_arty_a7/gpio/	User GPIO routines that reference Xilinx GPIO driver.
software/m3_for_arty_a7/main/	Top-level files.
software/m3_for_arty_a7/spi/	SPI routines that reference the SPI driver.
software/m3_for_arty_a7/uart/	User UART routines that reference Xilinx UART driver.
software/m3_for_arty_a7/sdk_workspace/	Location of <i>Software Development Kit</i> (SDK) build <i>Board Support Package</i> (BSP) files.

## 6.3 Example design reference files

A number of reference design files are provided with the delivery.

The following table describes these example design reference files in hardware  
`\m3_for_arty_a7\m3_for_arty_a7`.

**Table 6-2 Example design reference files in hardware\m3\_for\_arty\_a7\m3\_for\_arty\_a7**

File	Description
<code>bram_a7.elf</code>	Example design software binary for Cortex-M processors with debug symbols in <code>Elf_Dwarf</code> format.
<code>bram_a7.hex</code>	Example design software hex file loaded into FPGA build of Cortex-M <i>Instruction Tightly Coupled Memory</i> (ITCM).
<code>m3.mmi</code>	Example design memory map information. This is used to merge <code>elf</code> and <code>bit</code> files.
<code>m3_for_arty_reference.bit</code>	Example design with software included to load into FPGA RAM.
<code>m3_for_arty_reference.mcs</code>	Example design with software included to load into Arty board configuration flash.

The following table describes these example design reference files in software  
`\m3_for_arty_a7\Build_Keil`.

**Table 6-3 Example design reference files in software\m3\_for\_arty\_a7\Build\_Keil**

File	Description
<code>bram_a7.elf</code>	Example design software binary for Cortex-M processors with debug symbols in <code>Elf_Dwarf</code> format.
<code>bram_a7.hex</code>	Example design software hex file loaded into FPGA build of Cortex-M ITCM.
<code>qspi_a7.bin</code>	Example design software binary in QSPI format. This can be loaded by drag-and-drop using V2C-DAPLink mass storage.
<code>qspi_a7.hex</code>	Example design software hex file in QSPI format.

## 6.4 Generating the Arty A7 board support package

Before compiling the example software design that you are provided, a *Board Support Package* (BSP) is created using the *Vivado Software Development Kit* (SDK). The example software design includes files and directories that the BSP creates.

To generate a Cortex-M3 BSP for the Arty *Artix 7* (A7) board:

### Procedure

1. Open Vivado.
2. Open the design found in `V:/hardware/m3_for_arty_a7/m3_for_arty_a7/m3_for_arty_a7.xpr`.
3. If the original design has been modified, including changing the address map, then proceed and follow steps 4 and 5. If the hardware design is unchanged, proceed to step 6.
4. Select *Generate Block Diagram* from the left-hand side pane and then select *Generate*. This directs Vivado to generate the file required files for synthesis, implementation, and simulation for the block diagram.
5. Select `File` → `Export Hardware`. Set the *Exported location* to `V:/software`. The dialog box that opens prompts that an exported module for the file is already found. Click `Yes` to overwrite this file.

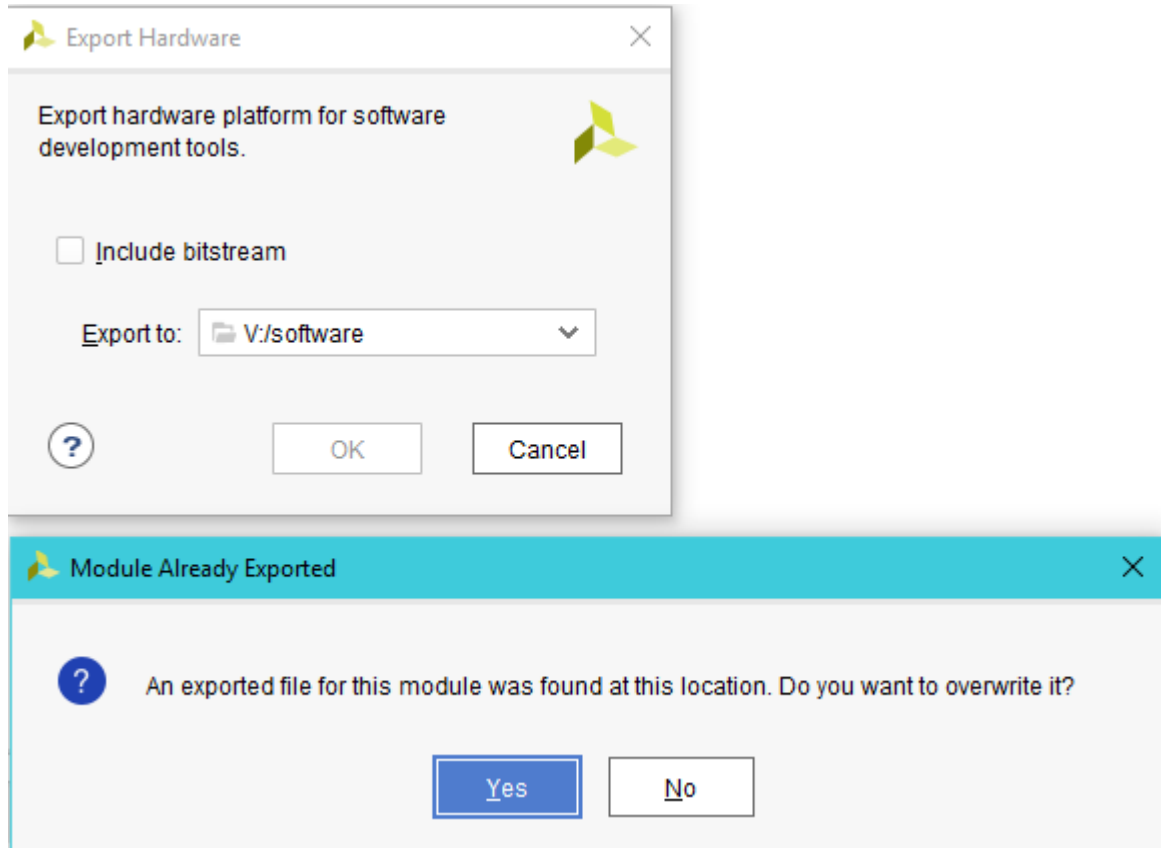
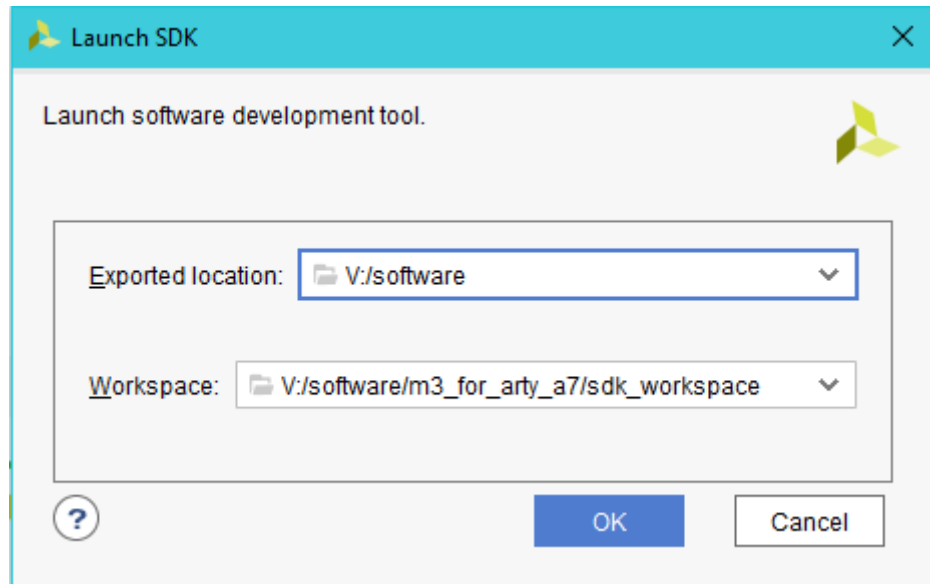

Figure 6-1 Export Hardware

6. Select `File` → `Launch SDK`. Set *Exported location* to `V:/software` and workspace to `V:/software/m3_for_arty_a7/sdk_workspace`. Click `OK` to proceed.



**Figure 6-2 Launch SDK**

7. Vivado SDK launches and automatically opens the hardware platform specification for the Arty A7 example design. The following image shows the memory map that is displayed. The memory map displayed aligns with the map described in [4.3 Memory map on page 4-38](#).



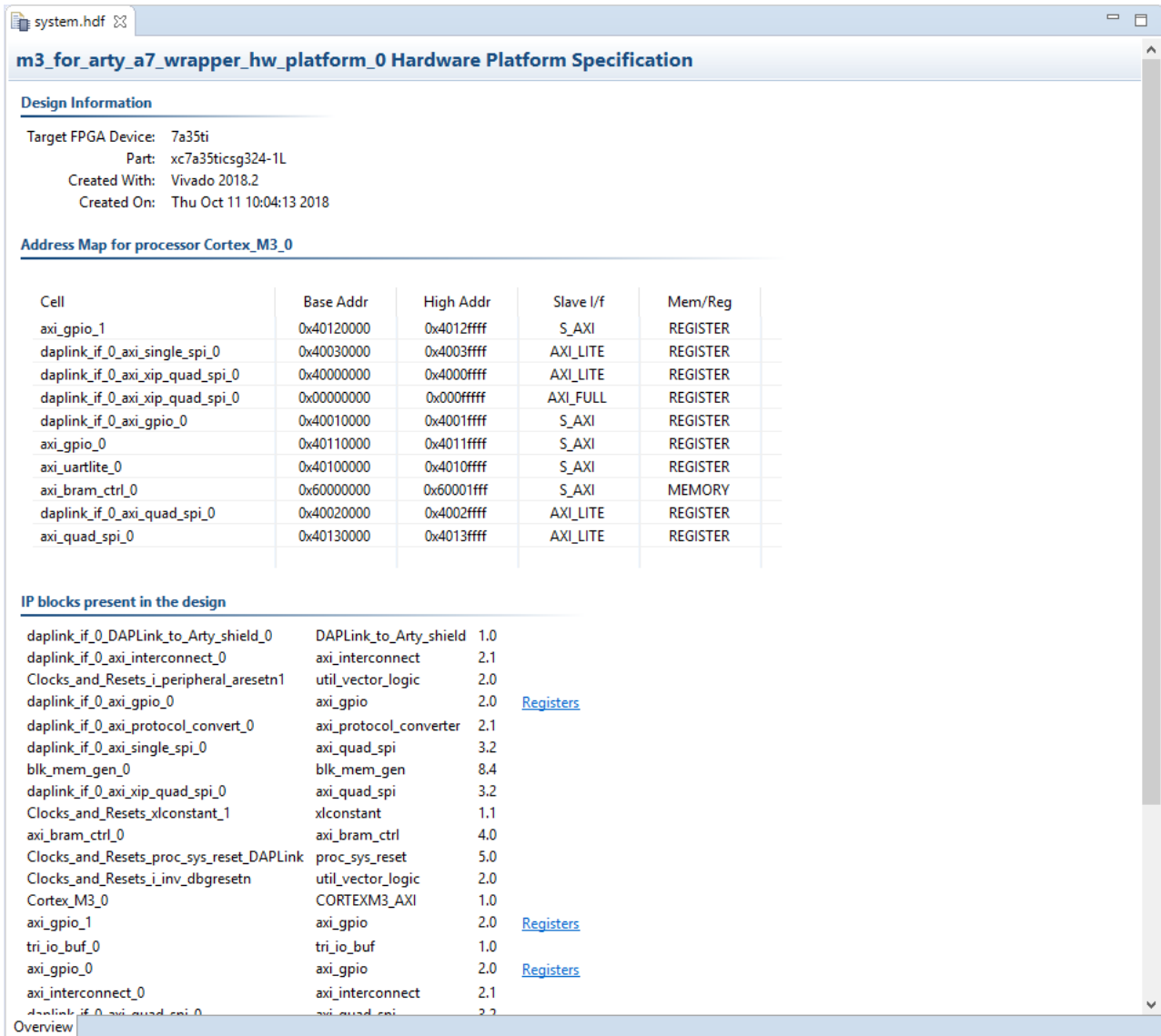

Figure 6-3 Memory map

- a. Confirm that under Xilinx → Repositories, the global repository list includes V:/vivado/Arm\_sw\_respository.
8. Select File → New → Board Support Package.
9. Set the design name to standalone\_bsp\_0.
10. Click Finish.

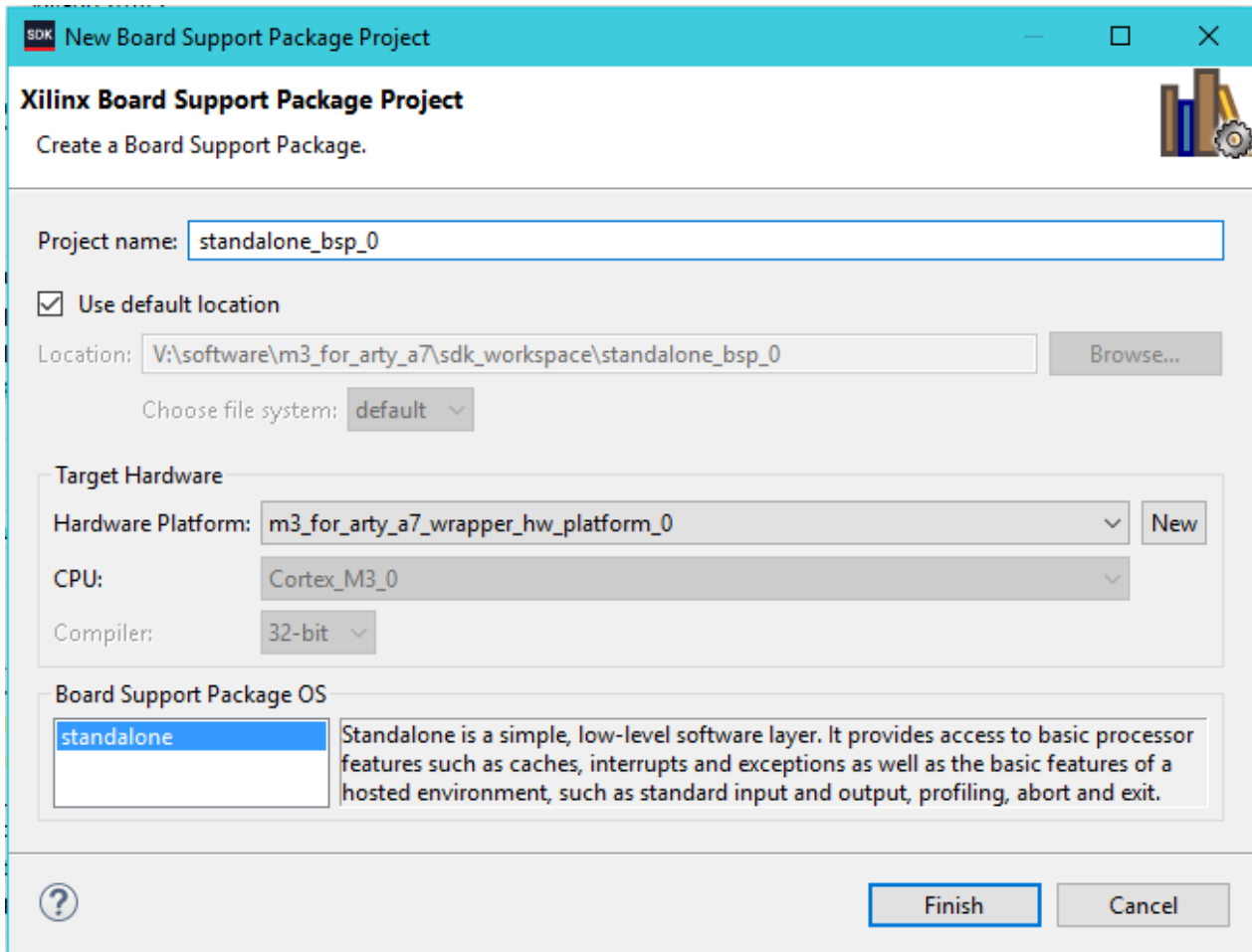

Figure 6-4 New Board Support Package Project

- a. On the next screen, confirm the OS version is 6.7. Additionally, on the Standalone tab, ensure that **stdin** and **stdout** are set to use **axi\_uartlite\_0**.

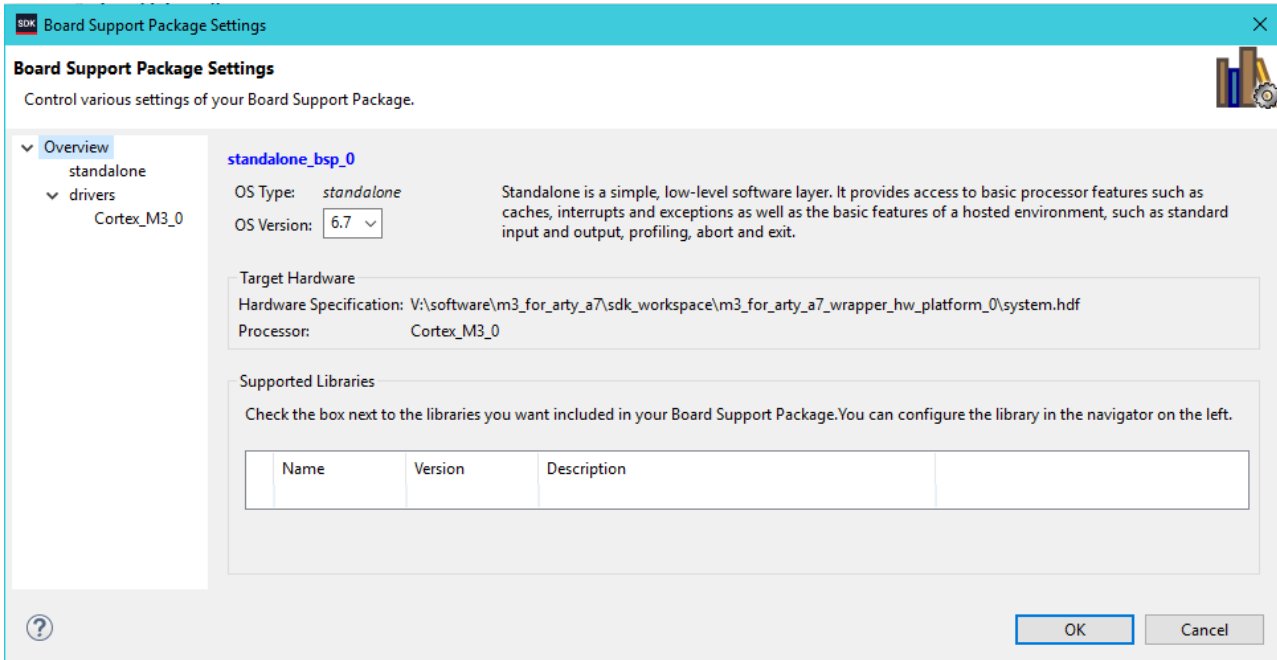

Figure 6-5 Board Support Package Settings - Overview tab

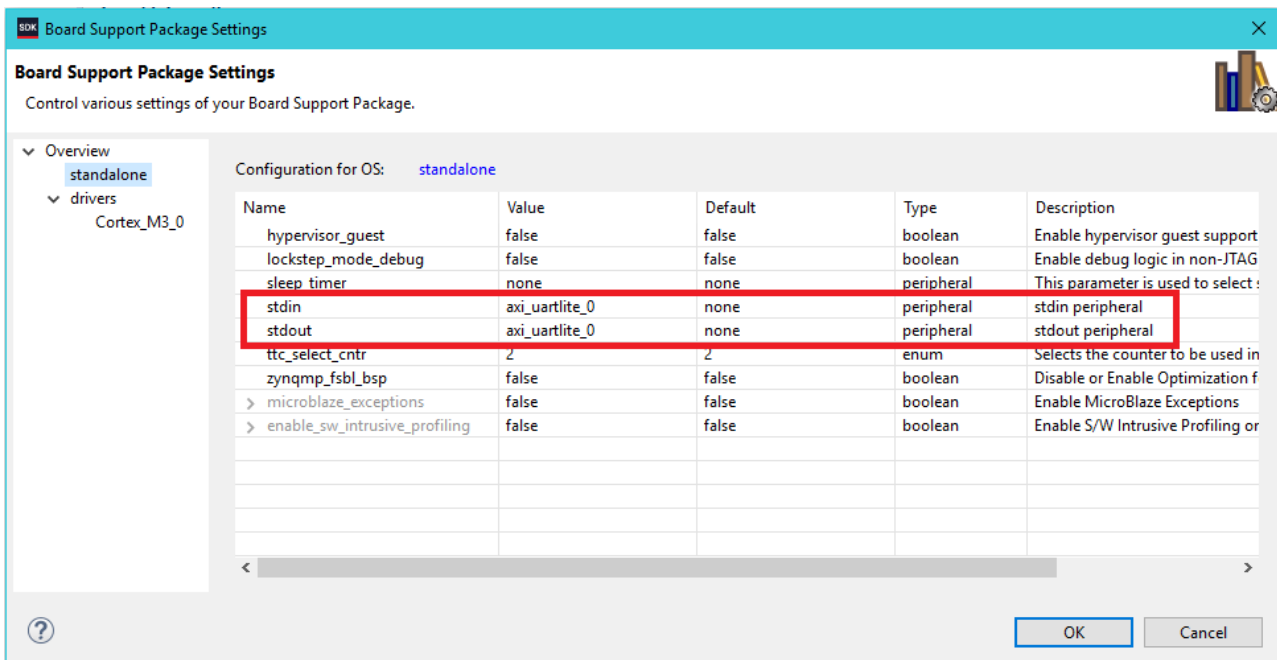

Figure 6-6 Board Support Package Settings - standalone tab

b. Click Finish. The SDK generates the required BSP files.

- The following directory structure now exists as V:/software/m3\_for\_arty\_a7/sdk\_workspace/standalone\_bsp\_0/CORTEX\_M3\_0/. The common Xilinx include files are in the /include directory. The driver files for the selected peripherals and the standalone BSP core files are in the /libscr directory.
- The xpseudo\_asm\_rcvt.h and xpseudo\_asm\_rcvt.c files must be manually copied from V:/vivado/Arm\_sw\_respository/CortexM/bsp/standalone\_v6\_7/src/arm/cortexm3/armcc to V:/software/m3\_for\_arty\_a7/sdk\_workspace/standalone\_bsp\_0/CORTEX\_M3\_0/include directory

because of differences between the Vivado SDK and Arm Keil *Microcontroller Development Kit* (MDK).

The BSP is complete and is now ready for use by the example software design for compilation.

---

**Note**

The BSP header file, `xparameters.h`, is located in the `V:\software\sdk_workspace\m3_for_arty_a7\standalone_bsp_0\CORTEX_M3_0\include`. This header file includes definitions for all memory addresses and peripheral configurations. It is automatically generated from the hardware platform specification. To enable tightly coupled hardware and software configurations Arm recommends that you use the configuration definitions from this file.

---

**Caution**

If the `xparameters.h` file does not contain entries for `STDIN_BASEADDRESS` or `STDOUT_BASEADDRESS`, then the `stdin` and `stdout` locations are not correctly set. This results in no UART output. The `standalone_bsp_0` directory should be removed, and the BSP regenerated.

---

**Next Steps**

You must now proceed to [6.5 Building the example software design on page 6-77](#).

## 6.5 Building the example software design

The example software design is built using the Arm Keil *µVision Microcontroller Development Kit* (MDK) tool.

To build the example software design:

### Prerequisites

You must complete the steps in [6.4 Generating the Arty A7 board support package on page 6-71](#).

### Procedure

1. Open Arm Keil *µVision MDK* and navigate to Project -> Open Project.
2. Select `V:/software/m3_for_arty_a7/Build_Keil/m3_for_arty_a7.uvprojx`.
3. Ensure that the target is `m3_for_arty_a7`.
4. Navigate to Project -> Rebuild. This rebuilds all target files.

### 6.5.1 Software design post processing

The target file, `m3_for_arty_a7.axf`, is generated in `/Build_Keil/objects`.

There is a post-process batch file, `make_hex_a7.bat` that the design calls automatically when the target is built. The batch file converts the `.axf` file to suitable `.hex`, `.bin`, and `.elf` files. The batch file automatically copies the relevant output files to the appropriate hardware project directories.

Therefore, when the design is rebuilt in Arm Keil *µVision Microcontroller Development Kit* (MDK), new `.elf` and `.hex` files are present in the filepath `V:/hardware/m3_for_arty_a7/m3_for_arty_a7.`

#### Note

For V2C-DAPLink drag and drop operation, `qspi_a7.bin` is created as part of the software design post processing process. This file is present in the `/Build_Keil` directory. This file can be directly copied to the V2C-DAPLink drive. The `.hex` file that the batch file generates is intended for use with the Vivado tools, and it does not work for drag and drop programming.

#### Caution

If the example design has no output to the UART, but the rest of design runs correctly on the board, that is, the LEDs respond to the push button changes, the cause is the generation of the standalone BSP, in particular, the setting of the `stdin` and `stdout` locations. For more information on changing the `stdin` and `stdout` locations, see [6.4 Generating the Arty A7 board support package on page 6-71](#). You must delete the current `standalone_bsp_0` directory and regenerate.

## 6.6 Software update flow

To avoid rebuilding the FPGA each time the software is modified, you can update the BRAM memories content in an existing bit file with the new software content.

This mechanism requires the following:

- A bit file of latest hardware design, containing the Cortex-M3 processor data and instruction memories inferred as RAM36 primitives.
- A *Memory Map Information* (MMI) file. The MMI file lists the mapping of the Cortex-M3 buses to the RAM36 primitives, and their location. The MMI file only changes when the hardware has been rebuilt. It does not require regeneration for each software iteration.
- A Software .elf file output from the software compilation tool flow.
- A batch file to combine these three files and produce a new bit file.

### 6.6.1 Generating the MMI file

The *Memory Map Information* (MMI) file maps the bit lanes from the data and instruction buses in the Cortex-M3 processor to specific RAM36 primitives and their locations.

The MMI file is updated whenever the FPGA design is rebuilt and a new bit file generated.

————— **Note** —————

It is not necessary to produce an MMI file each time the software is rebuilt. The MMI file reflects the current hardware build within the FPGA, and as such it is paired with each bit file.

You must generate the MMI file manually following these steps:

#### Procedure

1. In Vivado, after a bit file is produced, open the implemented design.
2. Open the TCL console.
3. Navigate to `V:/hardware/m3_for_arty_a7/m3_for_arty_a7`.
4. To create the file `m3.mmi` in the current directory, at the prompt type `source make_mmi_file.tcl`.

### 6.6.2 Generating bit and flash files

In the `V:/hardware/m3_for_arty_a7/m3_for_arty_a7` folder, there is a Windows batch file, `make_prog_bit.bat`. The `make_prog_bit.bat` file combines the `m3_for_arty_a7_wrapper.bit`, `m3.mmi`, and `bram_a7.elf` files into a bit file, `m3_for_arty_a7.bit` and a flash file `m3_for_arty_a7.mcs`.

To create a new `m3_for_arty_prog.bit` bit file in the current directory:

#### Prerequisites

The `make_prog_bit.bat` batch file requires that:

- A `m3_for_arty_a7_wrapper.bit` bit file is in `\m3_for_arty_a7_35.runs\impl_1\`.
- An `m3.mmi` file is in the current directory.
- A `bram_a7.elf` file is in the current directory.

The Vivado executable must be in your path. To test this, open a command window or console, and type the following:

```
vivado
```

#### Procedure

1. Open a command window in the `V:/hardware/m3_for_arty_a7/m3_for_arty_a7` folder.
2. Check that the `make_prog_bit.bat` file is configured.

3. At the prompt, execute the `make_prog_bit.bat` file.
4. Check the console messages to ensure that both `m3_for_arty_a7.bit` and `m3_for_arty_a7.mcs` files have been generated.

### 6.6.3 Programming

To program the example software design:

#### Procedure

1. In Vivado, open the hardware manager and auto-connect to the Arty *Artix 7* (A7) board.
2. Select *Program Device*. By default, Vivado selects the original bit file created `m3_for_arty_a7_wrapper.bit`.
3. Navigate to `V:/hardware/m3_for_arty_a7/m3_for_arty_a7`.
4. Select the `m3_for_arty_prog.bit` file generated in [6.6.2 Generating bit and flash files on page 6-78](#).
5. Select *Program*. The bit file with the latest software updates is now programmed on the board.

# Appendix A

## Revisions

This appendix describes the technical changes between released issues of this document.

It contains the following section:

- [A.1 Revisions on page Appx-A-81.](#)



## A.1 Revisions

This appendix describes the technical changes between released issues of this book.

**Table A-1 Issue 0000\_00**

<b>Change</b>	<b>Location</b>	<b>Affects</b>
First release	-	None